

Measurement of specific heat capacity for various metals

While conducting this experiment, you will be assessed for CPAC3: Working Safely.
Your lab report will be assessed for CPAC5: Referencing standard values.

Apparatus/Diagram

Aluminium, copper, brass and iron cylinders
12 V immersion heater
Power Supply
Ammeter
Voltmeter

Stopwatch
Lagged box
Heat-proof mat
Wires
Thermometer

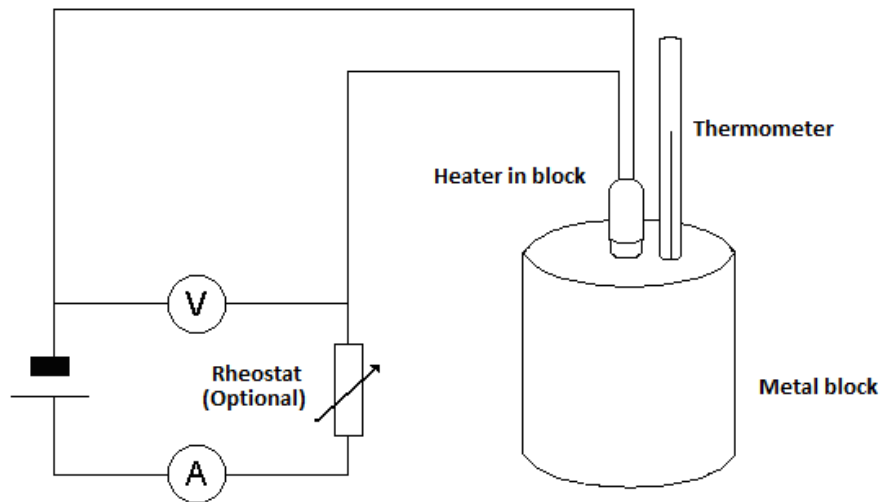

Theory

Assuming that the transfer of energy is 100% efficient:

Electrical energy supplied = energy gained by the block
 $\text{p.d.} \times \text{current} \times \text{time} = \text{mass} \times \text{specific heat capacity} \times \text{temperature change}$

so: $\text{specific heat capacity} = \frac{\text{p.d.} \times \text{current} \times \text{time}}{\text{mass} \times \text{temperature change}}$

If a graph of temperature against time is plotted then the gradient of the straight-line section of the graph is:

$\text{Gradient} = \frac{\text{temperature change}}{\text{time}}$

So:

$\text{Specific heat capacity} = \frac{\text{p.d.} \times \text{current}}{\text{mass} \times \text{gradient}}$

Method

Determine the mass of the block using a balance. Assemble the apparatus as indicated in the diagram, with the block in the lagged box. Switch on the power supply and start the stopwatch. Note the temperature of the block every 30 seconds. Record the voltmeter reading and ammeter readings. You don't need to use a rheostat to adjust these, but should monitor them and calculate and average. When the block has been heated for at least 6 minutes, turn off the power supply. Continue to record the temperature of the block until a maximum value is reached. **Determine the gradient of the straight line section of the graph.** Repeat this for each block.

CAUTION: the blocks may be quite hot afterwards. Use a cloth if necessary to handle them and leave them on the heat-proof mat.

Analysis

Plot a graph of temperature against time for each metal.

Can you explain the shape of your temperature – time graphs?

Measure the gradient of the straight-line section and use this with the other values to calculate the specific heat capacity of each metal.

The values obtained should be compared with the standard values from a data book. Evaluate the percentage difference between your values and the standard values.

The percentage uncertainties for each of the measurements of p.d., current, time, temperature and mass should be evaluated so that you can discuss their relative importance in contributing to the percentage error.

This is not the only sort of error in an experiment of this nature. The assumption that the energy transfer is 100% efficient will never be true as there will always be some heat lost from the apparatus. Consider what effect this will have on your graph and discuss whether this should lead to a lower or higher value for the s.h.c.