

CamJam EduKit Robotics – Distance Sensor

Project Ultrasonic distance measurement

Description In this worksheet you will use an HR-SC04 sensor to measure real world distances.

Equipment Required

For this worksheet you will require:

- Your robot, including the line follower installed in the last worksheet
- The HR-SC04 ultrasonic module
- Jumper leads (4 Male-Male)
- 330Ω resistor
- 470Ω resistor

You will be adding the distance sensor to the breadboard used in the previous worksheet, and connecting it to the EduKit Motor Controller Board.

HR-SC04 Ultrasonic Module

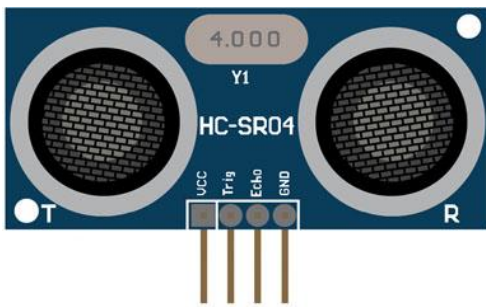

The HR-SC04 Ultrasonic Sensor module is used to detect the distance from the sensor to a surface.

How it works

The Trigger: When the sensor is triggered by a voltage being applied to the Trig pin, it sends a high pitched (ultrasonic) sound from the speaker marked T (transmit). The voltage is only applied for 10 microseconds (0.00001 seconds).

The Echo: When the sound is heard by the receiver (marked R), the Echo pin is 'taken high', which means that it is made to provide 5 volts.

By timing how long it is between the sound being produced and the sound being detected, and making a calculation, it is possible to work out the distance between the sensor and an object in front of it.

The echo pin should stay high however long it takes the pulse to return. You work out the distance from how long the pulse is using the following formulae:

$$\text{distance} = \text{elapsed} * 34326$$

where:

elapsed is the length of the pulse (the time between trigger and echo) in seconds

34326 is the speed of sound in cm/s

Since the ultrasound has to travel both to the object and echoed back from the object, it has covered twice the distance. Therefore, you need to halve the distance:

$$\text{distance} = \text{distance} / 2.0$$

The HR-SC04 requires 5 volts to work. This is fed from the Raspberry Pi via the EduKit Motor Controller Board. It also outputs 5 volts on the Echo pin. However, the Raspberry Pi GPIO input pins should only be supplied with 3.3 volts. Therefore, you are going to use what is known as a 'voltage divider' to split the

output voltage between the GPIO input pin and the ground pin. This is made using resistors on the ultrasonic sensor's output pin, diverting some voltage to the GPIO input pin with the rest going to 'ground'.

GPIO Zero does all the distance calculations for you, simply returning the distance from a surface.

Resistors

Resistors are a way of limiting the amount of electricity going through a circuit; specifically, they limit the amount of 'current' that is allowed to flow. The measure of resistance is called the Ohm (Ω), and the larger the resistance, the more it limits the current. The value of a resistor is marked with coloured bands along the length of the resistor body.

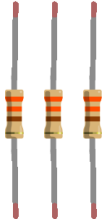

The EduKit is supplied with two sets of resistors. There are two 330Ω resistors and two 470Ω resistors. Only one of each is required; extras are supplied as spares. You can identify the resistors by the colour coding along the body. The colour coding will depend on how many bands are on the resistors supplied:

- If there are four colour bands:
 - The 330Ω resistor will be Orange, Orange, Brown, and then Gold.
 - The 470Ω resistor will be Yellow, Violet, Brown, and then Gold.
- If there are five colour bands:
 - The 330Ω resistor will be Orange, Orange, Black, Black, Brown.
 - The 470Ω resistor will be Yellow, Violet, Black, Black, Brown.

The resistors in this circuit will be acting as a 'voltage divider', reducing the voltage of the output from the ultrasonic sensor (5 volts) down to a level that the Raspberry Pi can handle (3.3 volts).

It does not matter which way round you connect the resistors. Current flows in both ways through them.

Note: You may find that your kit has been supplied with THREE sets of resistors. One set is marked Yellow, Violet, Black Brown, Brown ($4.7k\Omega$), and is not required.

Building the Circuit

The diagram below shows the HR-SC04 sensor plugged into the board, as well as the line follower on the right.

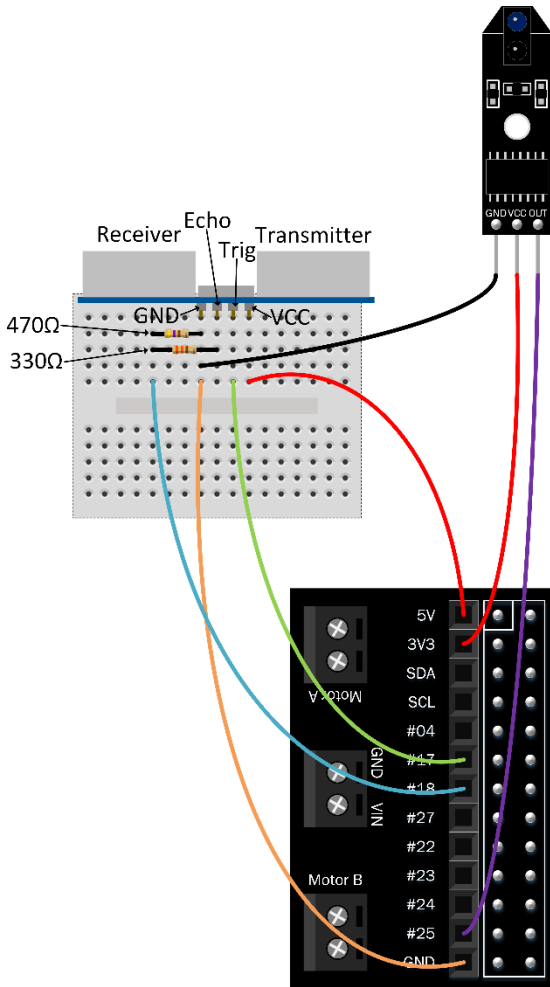

right.

Push the ultrasonic sensor into the holes on the breadboard, with the pin marked GND in the same column as the jumper wire that goes to the ground of the EduKit Controller Board.

Bend the legs of the two resistors and place them in the breadboard as on the diagram. Ensure that the correct resistors are placed in the right position. The 330Ω resistor (orange-orange-brown) goes between the Echo pin of the sensor and an unused column of the breadboard. The 470Ω resistor (yellow-purple-brown) goes between that same column and the ground (GND) pin. Then connect the breadboard column to socket 18 of the EduKit Controller Board.

Connect the row with the sensors' VCC connection (red wire in the diagram) to the EduKit Controller Board's 5v socket. The sonar module requires 5v to run.

Connect the column with the sensors' trigger (green wire in the diagram) to the EduKit Controller Board's socket marked #17 (The Pi's GPIO pin 17).

Remember: the echo pin of the sensor module is connected to the Raspberry Pi GPIO with resistors and ground because the module uses a +5V level for a "high", but this is too high for the inputs on the GPIO header, which only likes 3.3V. In order to ensure the Pi only gets hit with 3.3V you use a basic "voltage divider" formed with the two resistors.

Code

Create a new python script called 5-distance.py and type in the following code:

```
# CamJam EduKit 3 - Robotics
# Worksheet 6 - Measuring Distance

import time # Import the Time library
from gpiozero import DistanceSensor # Import the GPIO Zero Library

# Define GPIO pins to use on the Pi
pinTrigger = 17
pinEcho = 18

sensor = DistanceSensor(echo=pinEcho, trigger=pinTrigger)

print("Ultrasonic Measurement")

try:
    # Repeat the next indented block forever
    while True:
        print("Distance: %.1f cm" % sensor.distance * 100)
```

```
time.sleep(0.5)
```

```
# If you press CTRL+C, cleanup and stop  
except KeyboardInterrupt:  
    print("Exiting")
```

Running the Code

Run your code and move an object (e.g. your hand) in front of the sensor and watch the distance change.

Next Steps

The breadboard has double sided tape on the bottom. Remove the wax paper to stick it to the front of your robot so that the ultrasonic sensor points forward.