



Introduction

Critical Path Analysis (CPA) is a decision making tool, which can help a business to improve their efficiency. It is used to decide at what point certain activities can happen in a project. Just imagine a giant office block being built; it is pointless to schedule the carpet fitters to arrive on day one when the foundations of the building are still being dug. CPA will help a business to work out when the carpet fitters should arrive.



Figure 2: Foundations being dug

These two activities cannot happen at the same time



Figure 1: Carpet being fitted

Uses of CPA

- **To estimate the minimum time taken on a project by identifying the critical path of activities**
- **CPA is used to calculate the likely impact of a delay on the project**
- **It is used to help the business order materials when they are needed**
- **It is used to work out how long the non-critical activities could be delayed for**

Limitations of CPA

- **Having a CPA diagram does not mean that everyone working on the project will stick to the timings**
- **For larger and more complex projects the diagram would be too complicated to be useful**
- **It takes up management time to plan and draw the diagrams**
- **The CPA diagram does not give any information about costs or quality**
- **The CPA diagram sets deadlines which can put pressure on management and staff to complete on time**

CPA explained

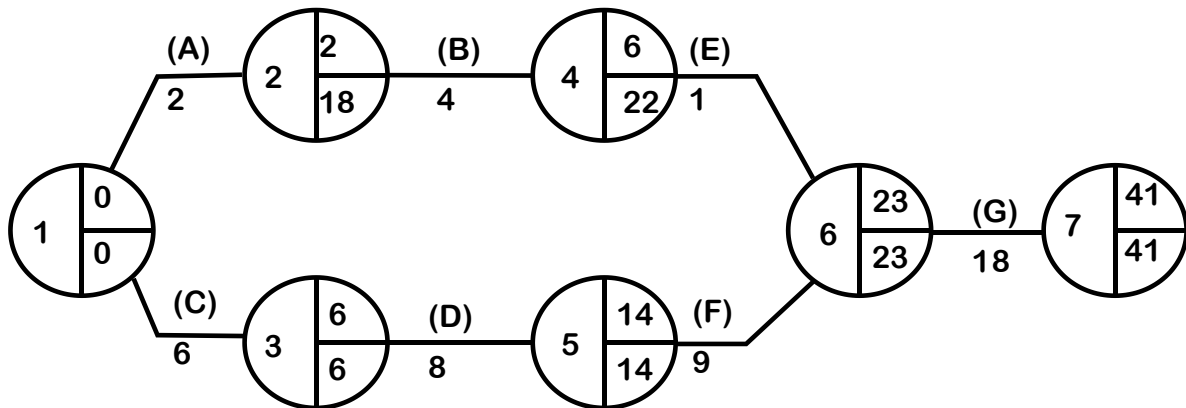

This is what a completed CPA diagram looks like.

The circles in a CPA diagram are called nodes, each node is given a number to identify it. Each node is divided into 3 parts...

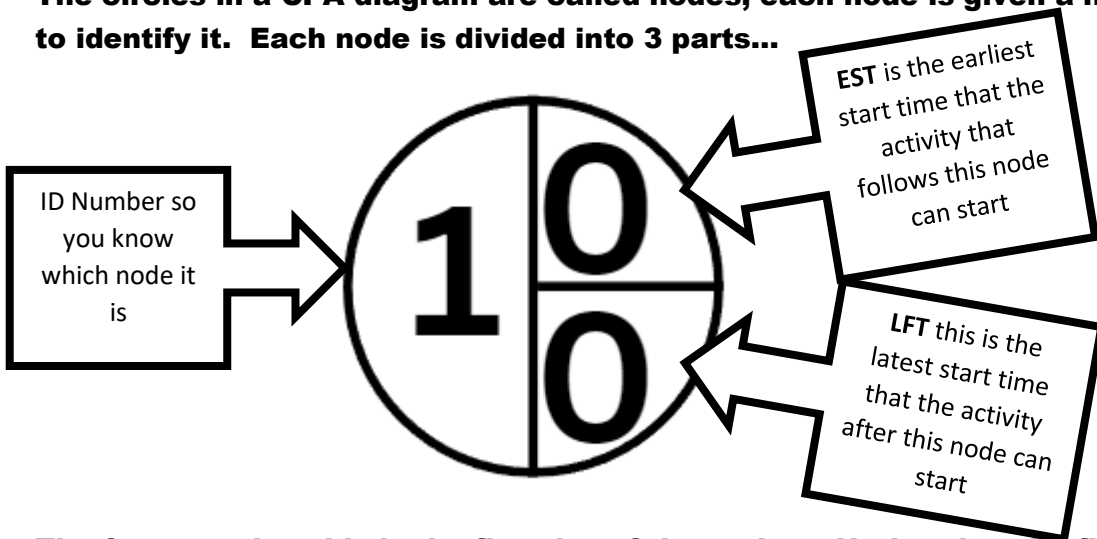

The 0 means that this is the first day of the project. Notice that the final node on the right ends on the same number of days, in this example its 41 days.

Activities to be carried out in the project would have a letter ABCDE and so on. The duration of the activity (how long it takes) is written on the line below the letter. So in this example the duration of A is 2 days. We add this to 0 to get an EST of 2. The LFT of this node will have been calculated from the node before it.

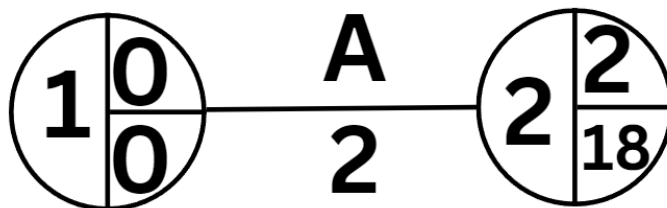

CPA step-by-step method

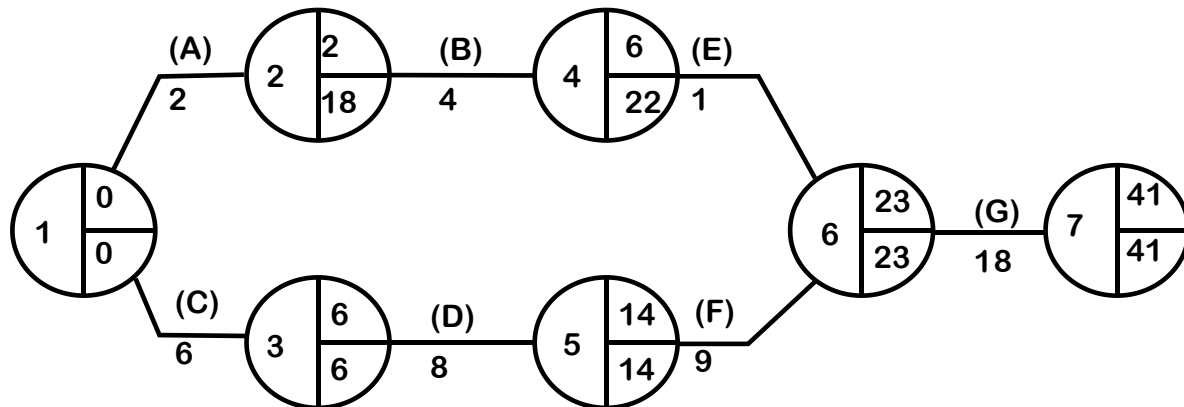

The diagram shows a series of activities and the duration. It helps a business to work out when resources should be delivered or other resources booked.

Method

- 1) Make sure node 1 is 00
- 2) Calculate all the ESTs by adding the duration into the top right hand part of the node
- 3) EST: When there is a choice (in this example at node 6) choose the highest figure
- 4) When you get to the final node copy the number of days into the LFT part of the same node, in this example 41
- 5) Now work backwards across your diagram minus the days and put the figures into the LFT part of the node.
- 6) LFT: When there is a choice choose the lowest figure (in this example at node 6)

EST - use highest number and work forwards

LFT - use lowest number and work backwards

CPA walkthrough example

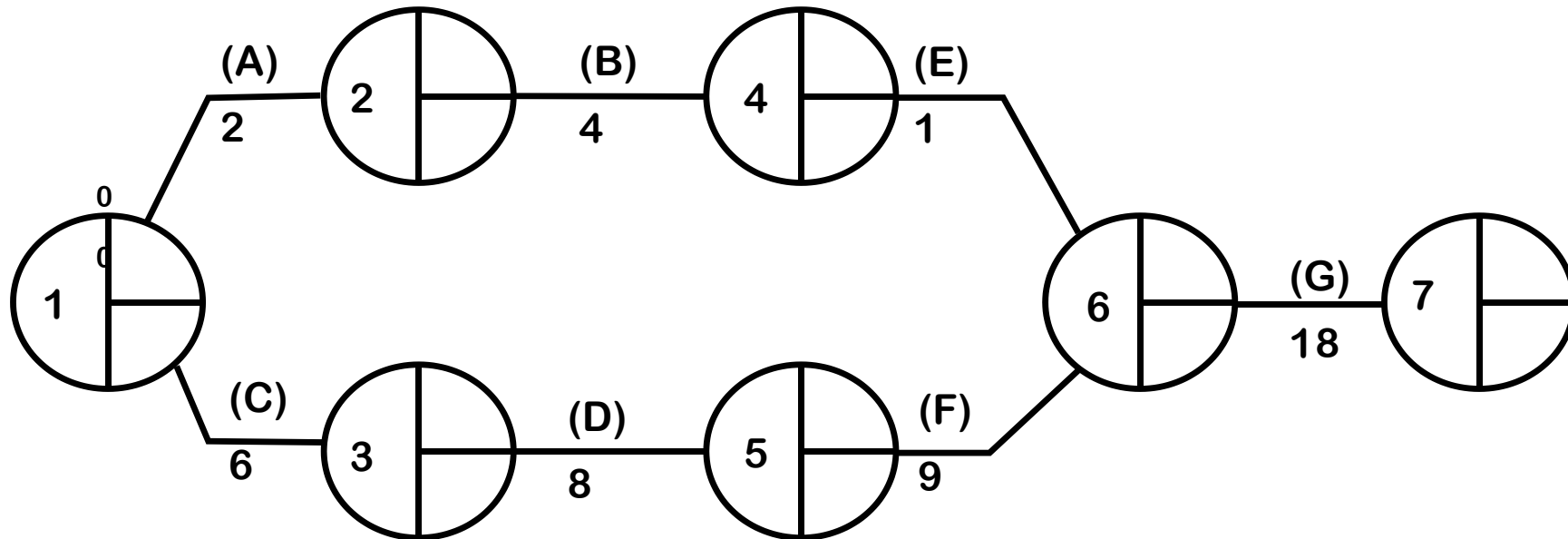

- 1. Notice at node 6 you get a choice of numbers. If you take the bottom path it will be 23, if you take the top path it would be 7. Choose the longest path: 23 for the EST because you need to know when you can start the next activity e.g. laying carpet and it can't happen until all the other activities are completed, day 23. If you use day 7 then there may be no floor to put the carpet down onto at that stage.**
- 2. At node 1 you have a choice again – the golden rule is that with LFT it is the lowest number (0) and it is also helpful to know that node 1 will always be 0 / 0, so you can fill that part in at the start.**

CPA how to identify the “critical path”

Now identify the critical path – these are the activities that have no slack (which we call float) and they are easy to spot because the numbers are the same top and bottom.

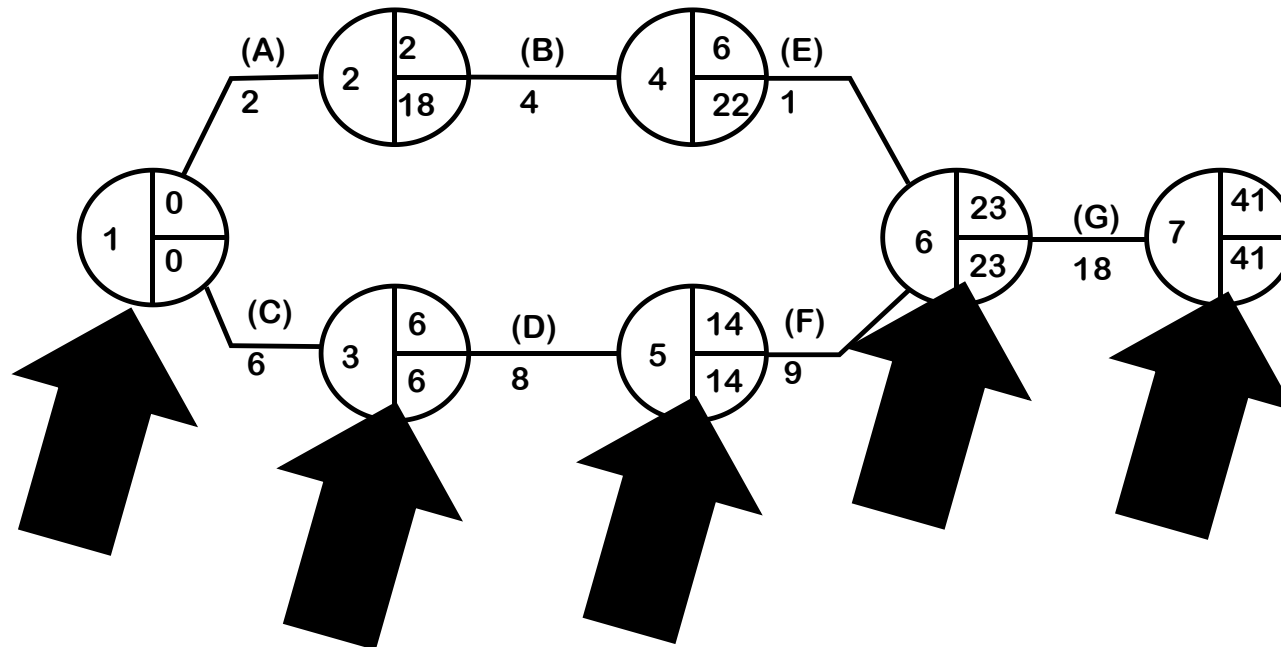

The activities with the arrows are the critical path. You should indicate it on your diagram with lines like this:

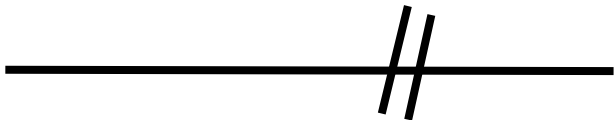

CPA how to calculate the float time

Now you can calculate the float time, these are activities that are not critical and can be delayed without the whole project being delayed. You are looking for nodes where the numbers are different top and bottom.

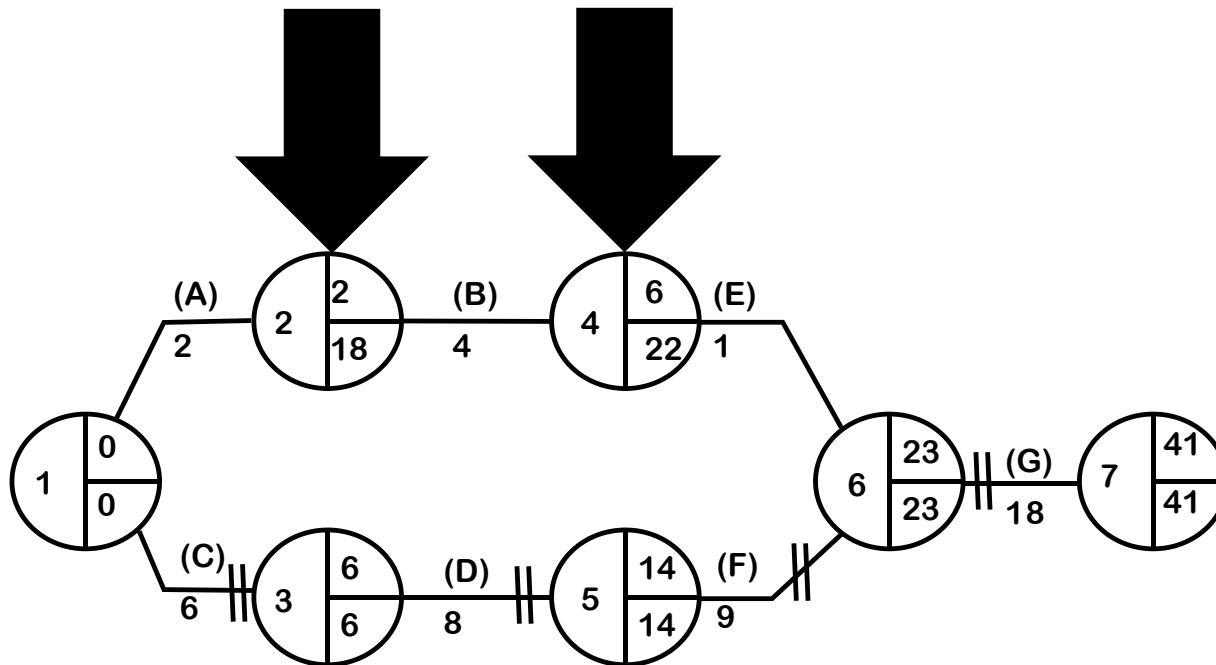

Float time for Activity A
 $18 - 2 - 0 = 16$

Float time for Activity B
 $22 - 4 - 2 = 16$

Total float time for the project = 16 + 16 = 32

To calculate float

Float time = LFT - Duration - EST of previous

An alternative method to using the formula is to look for all the nodes where the EST and LFT are different. Add up all the differences to calculate the total float time.

Calculate the EST, LFT, mark on the critical path and calculate total float time for example 1.

Example 1

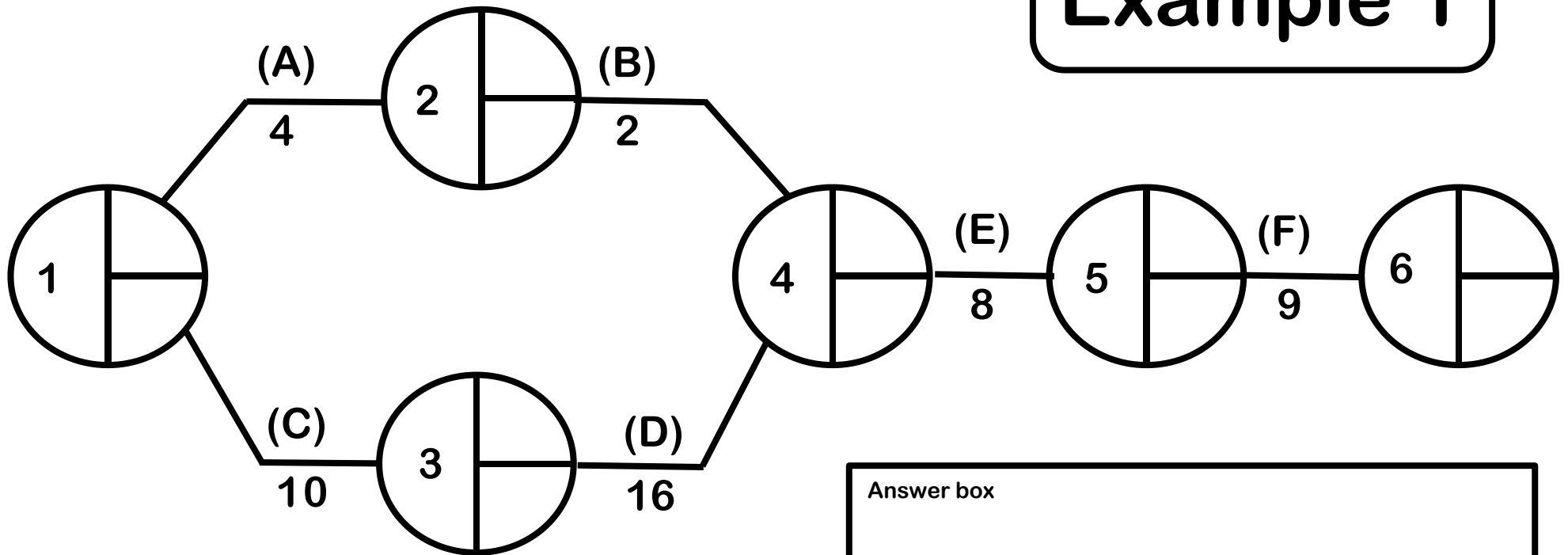

Answer box

Calculate the EST and LFT and the critical path and total float time for example 2.

Example 2

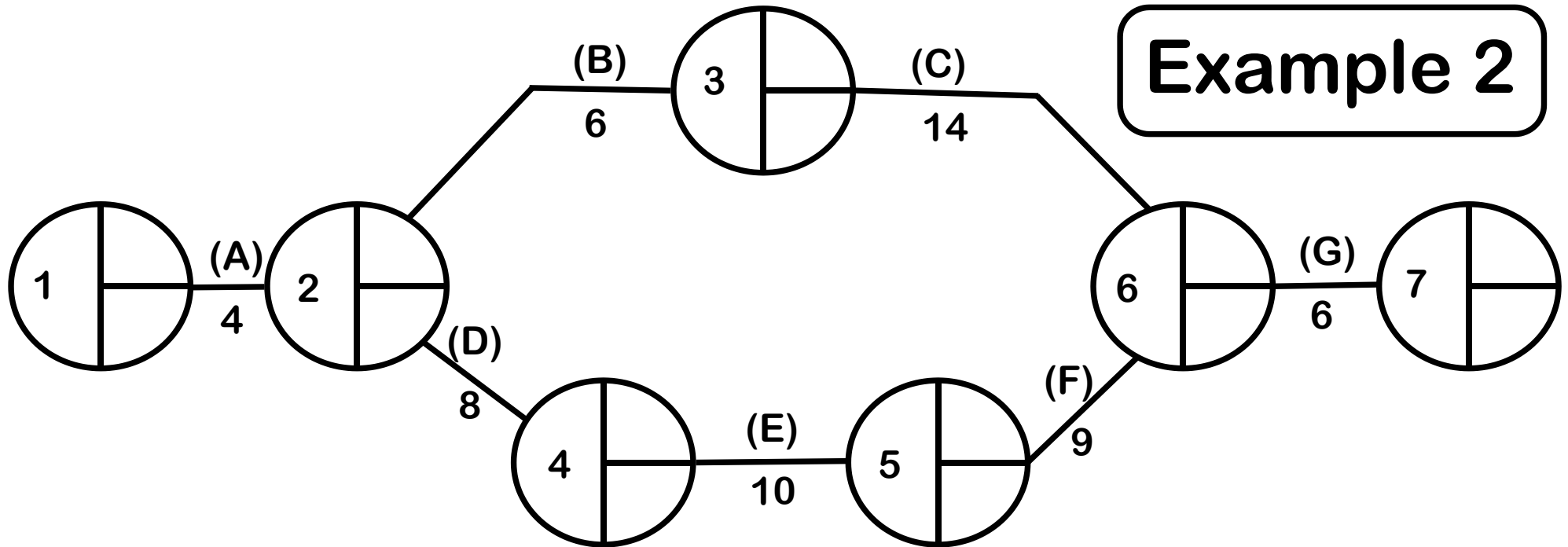

Answer box

Calculate the EST and LFT and the critical path and total float time for example 3.

Answer box

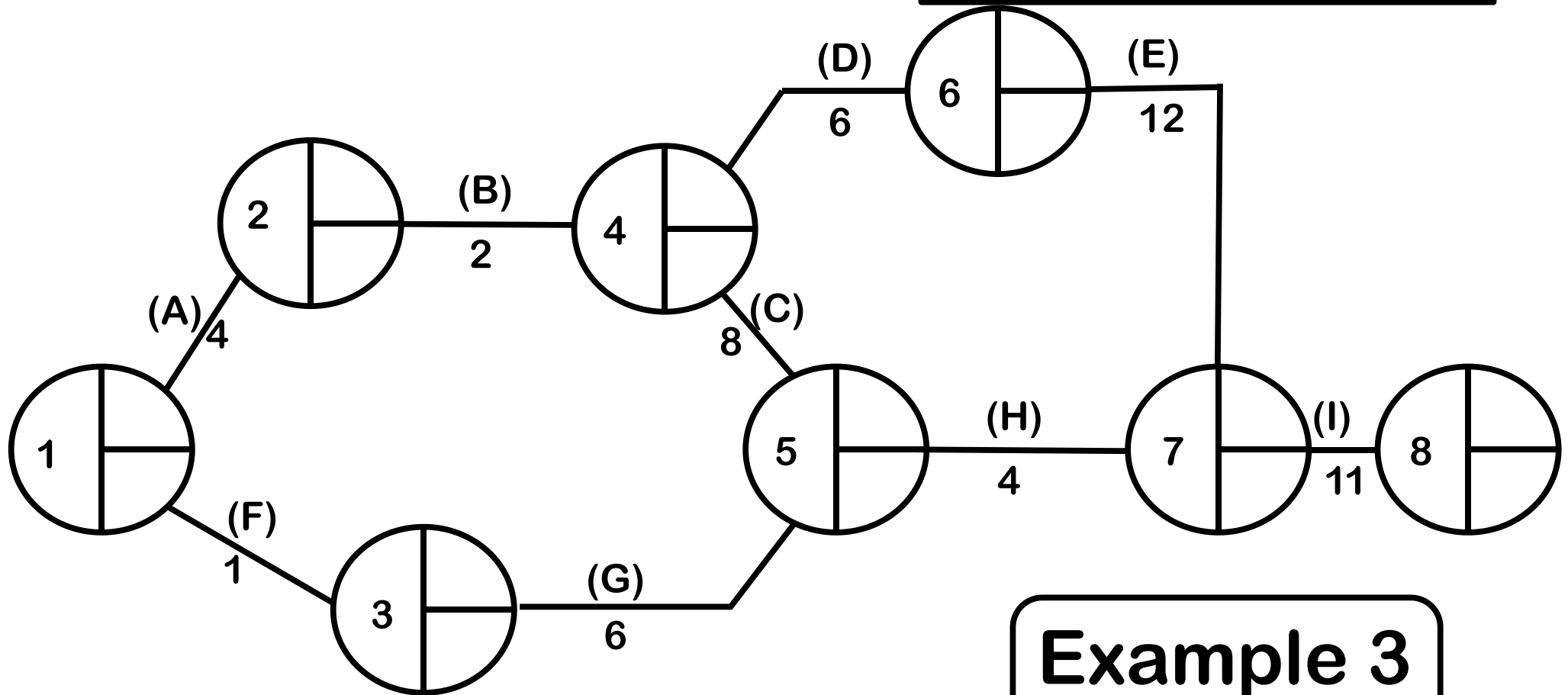

Example 3

Calculate the EST and LFT and the critical path and total float time for example 4.

Example 4

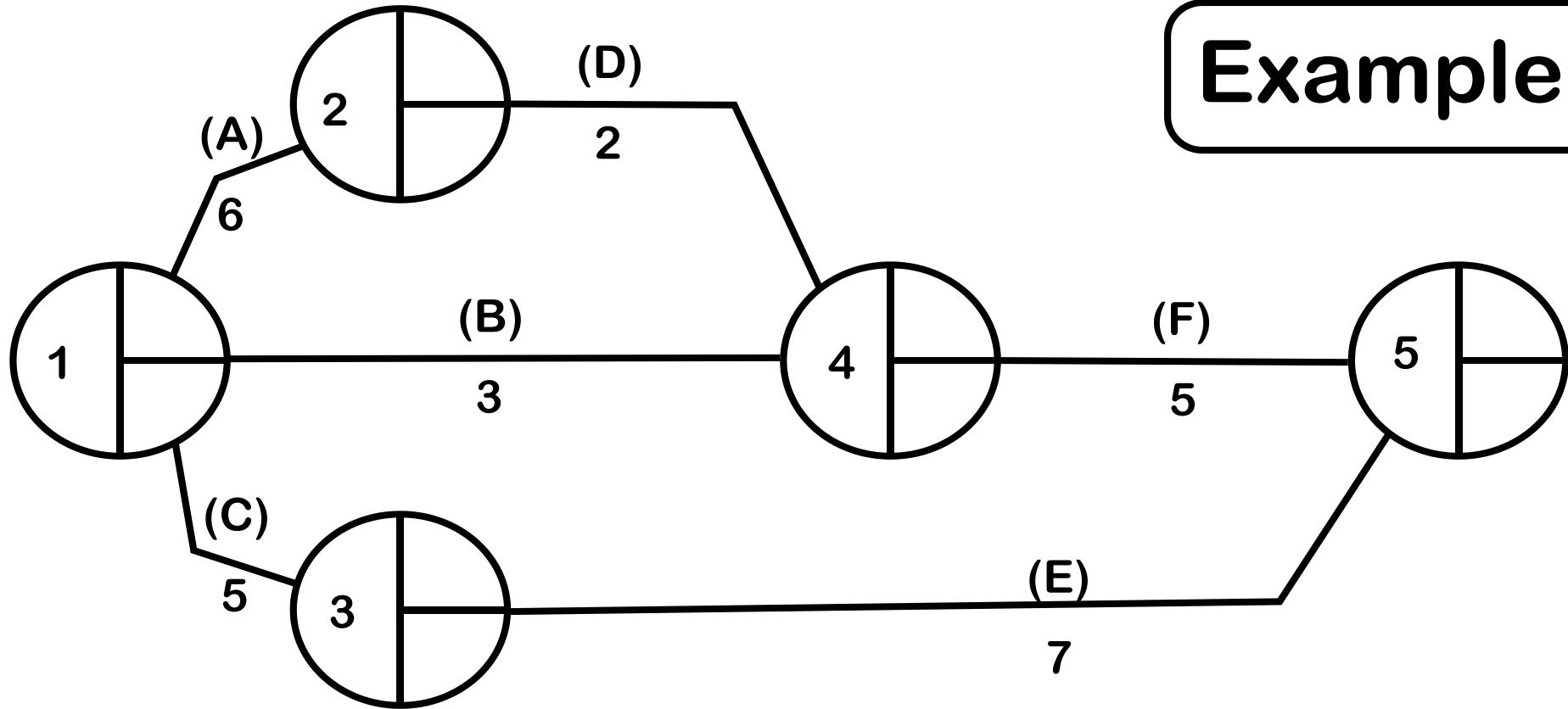

Answer box

Example 5

Calculate the EST and LFT and the critical path and total float time for example 5.

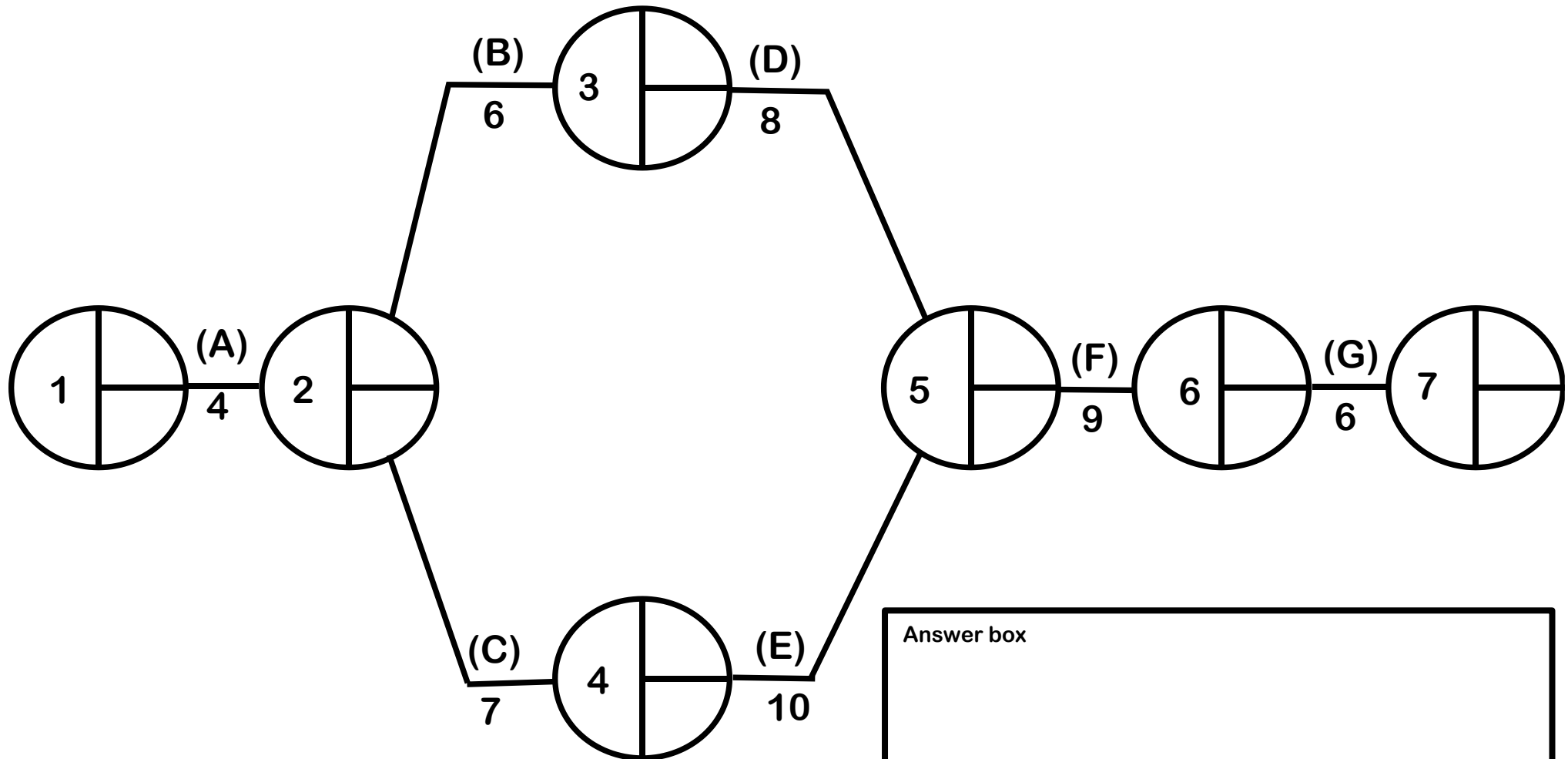

Answer box

Example 6

Calculate the EST and LFT and the critical path and total float time for example 6.

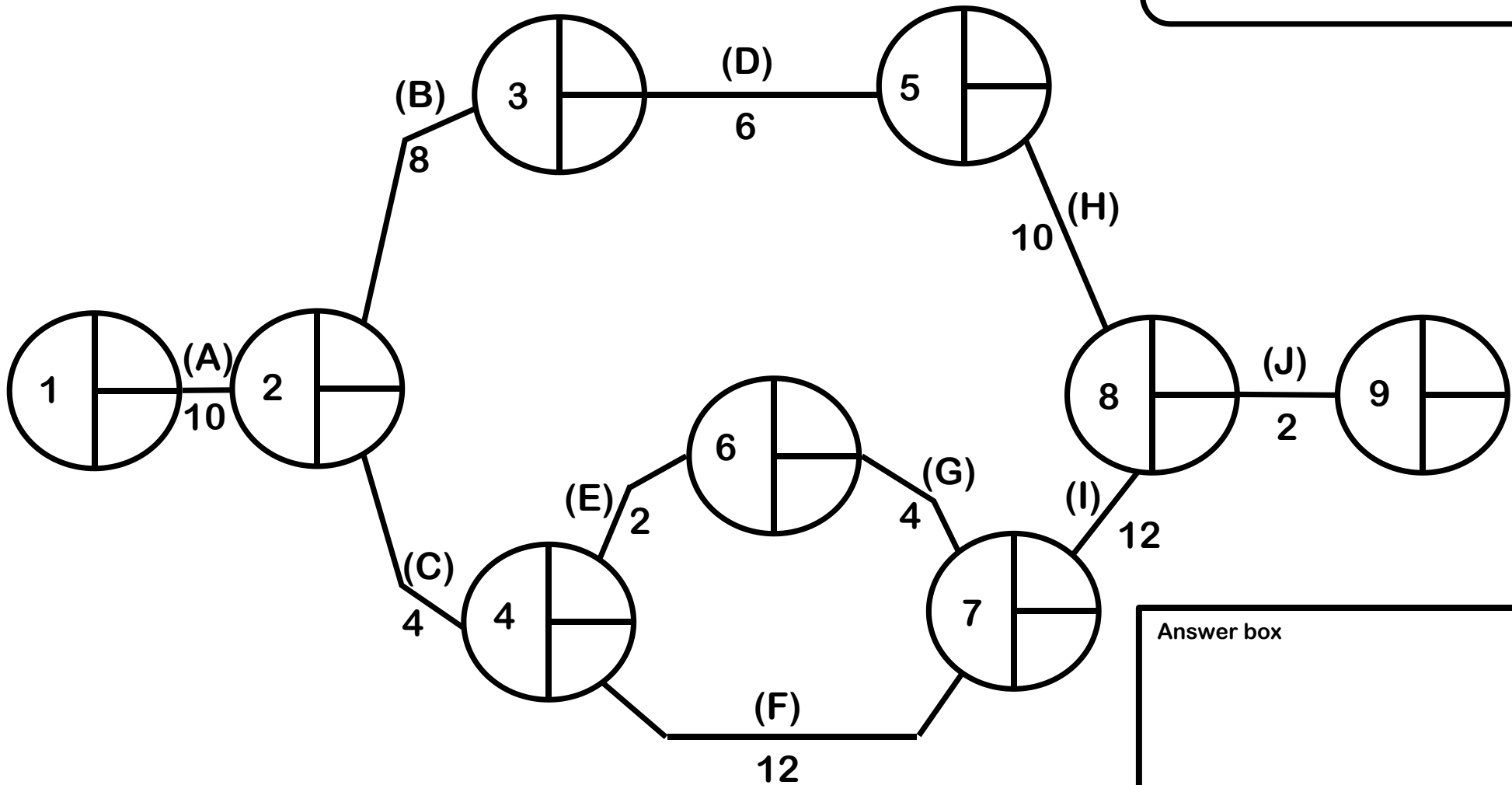

Answer box