

ANSWERS

Write your name here		
Surname	Other names	
Pearson Edexcel Level 1/Level 2 GCSE (9 - 1)	Centre Number	Candidate Number
	<input type="text"/> <input type="text"/> <input type="text"/> <input type="text"/> <input type="text"/>	<input type="text"/> <input type="text"/> <input type="text"/> <input type="text"/> <input type="text"/>
<b>Mathematics</b> <b>Paper 3 (Calculator)</b>		<b>Higher Tier</b>
Mock Set 1 – Autumn 2016 <b>Time: 1 hour 30 minutes</b>		Paper Reference <b>1MA1/3H</b>
<b>You must have:</b> Ruler graduated in centimetres and millimetres, protractor, pair of compasses, pen, HB pencil, eraser, calculator. Tracing paper may be used.		Total Marks

### Instructions

- Use **black** ink or ball-point pen.
- **Fill in the boxes** at the top of this page with your name, centre number and candidate number.
- Answer **all** questions.
- Answer the questions in the spaces provided  
– *there may be more space than you need.*
- **Calculators may be used.**
- If your calculator does not have a  $\pi$  button, take the value of  $\pi$  to be 3.142 unless the question instructs otherwise.
- Diagrams are **NOT** accurately drawn, unless otherwise indicated.
- You must **show all your working out.**



### Information

- The total mark for this paper is 80
- The marks for **each** question are shown in brackets  
– *use this as a guide as to how much time to spend on each question.*

### Advice

- Read each question carefully before you start to answer it.
- Keep an eye on the time.
- Try to answer every question.
- Check your answers if you have time at the end.

Turn over ►

S52628A

©2016 Pearson Education Ltd.  
6/6/71



PEARSON

Answer ALL questions.

Write your answers in the spaces provided.

You must write down all the stages in your working.

- 1 Buses to Ashby leave a bus station every 24 minutes.  
Buses to Barford leave the same bus station every 20 minutes.

A bus to Ashby and a bus to Barford both leave the bus station at 7:30 am.

When will a bus to Ashby and a bus to Barford next leave the bus station at the same time?

24, 48, 72, 96, 120  
20, 40, 60, 80, 100, 120

120 MINUTES = 2 HOURS

7:30 am + 2 HOURS = 9:30 am

9:30 am

(Total for Question 1 is 3 marks)



- 2 Amzol thinks that  $(x + 5)^2 = x^2 + 25$  for all values of  $x$ .

Is Amzol right?

You must show how you get your answer.

$$\begin{aligned}(x + 5)^2 &= (x + 5)(x + 5) \\ &= x^2 + 10x + 25 \\ &\neq x^2 + 25\end{aligned}$$

SO AMZOL IS NOT RIGHT

(Total for Question 2 is 2 marks)

- 3 Kim, Laura and Molly share £385

The ratio of the amount of money Kim gets to the amount of money Molly gets is 2:5  
Kim gets £105 less than Molly gets.

What percentage of the £385 does Laura get?

K	M	DIFFERENCE
2	5	3
70	175	105 $\downarrow$ $\times 35$

$70 + 175 = 245$  ie KIM AND MOLLY GET £245

$\therefore$  LAURA GETS  $385 - 245 = £140$ .

$$\frac{140}{385} \times 100 = 36.4\%$$

36.4 %

(Total for Question 3 is 4 marks)



4 The table shows information about the heights of 60 trees.

Height ( $h$ metres)	Frequency
$0 < h \leq 4$	13
$4 < h \leq 8$	24
$8 < h \leq 12$	15
$12 < h \leq 16$	6
$16 < h \leq 20$	2

Jacob drew this frequency polygon for the information in the table.  
The frequency polygon is **not** correct.

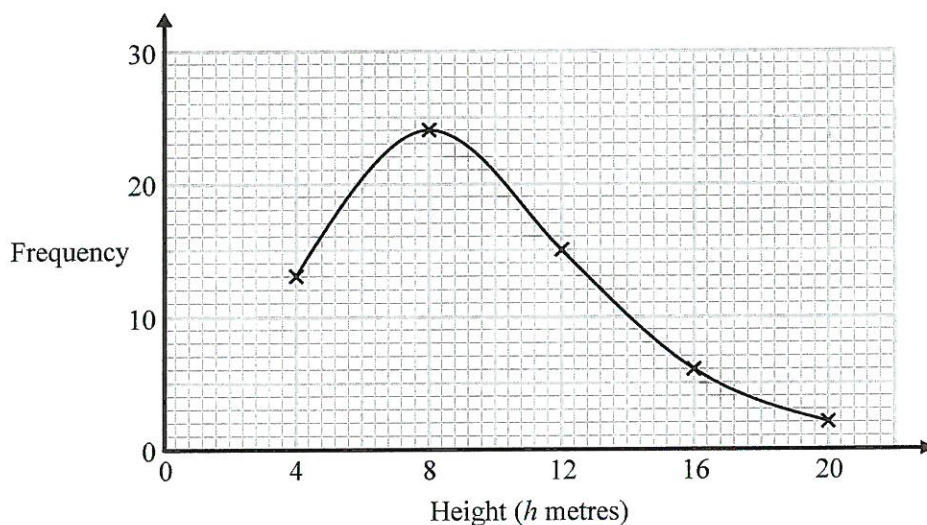

Write down **two** things that are wrong with the frequency polygon.

- 1 MIDPOINTS NOT USED
- 2 POINTS SHOULD BE JOINED BY STRAIGHT LINES, NOT CURVES

(Total for Question 4 is 2 marks)



- 5 The price of all rail tickets increased by 5%.  
The price of a rail ticket from London to Ipswich increased by £2.30

Work out the price of the ticket before the increase.

$$5\% \text{ is } £2.30$$

$$\therefore 100\% \text{ is } 20 \times £2.30 = £46$$

£ 46

(Total for Question 5 is 2 marks)



S 5 2 6 2 8 A 0 5 2 0

6

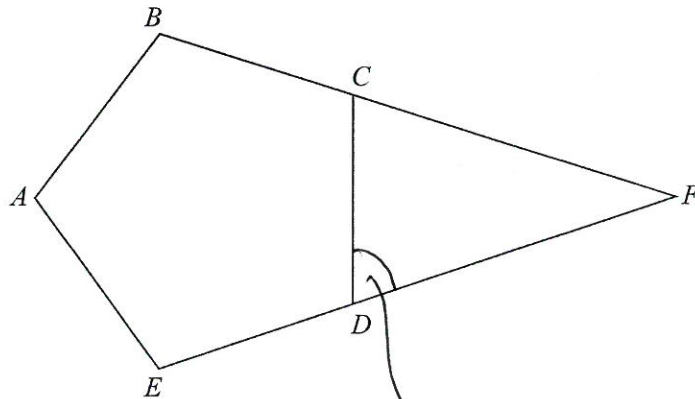

$ABCDE$  is a regular pentagon.  
 $BCF$  and  $EDF$  are straight lines.

Work out the size of angle  $CFD$ .  
 You must show how you get your answer.

EXTERIOR ANGLE OF  
 REGULAR PENTAGON  
 $= \frac{360}{5} = 72^\circ$

TRIANGLE  $CDF$  IS ISOSCELES  $\therefore \hat{C}F = \hat{D}CF = 72^\circ$

$$\begin{aligned} \therefore \hat{C}FD &= 180 - 2 \times 72 && \text{BECAUSE ANGLES IN A} \\ &= 180 - 144 && \text{TRIANGLE ADD UP TO } 180^\circ \\ &= 36^\circ \end{aligned}$$

36°

(Total for Question 6 is 3 marks)

6



S 5 2 6 2 8 A 0 6 2 0

DO NOT WRITE IN THIS AREA

DO NOT WRITE IN THIS AREA

DO NOT WRITE IN THIS AREA

- 7 A garden is in the shape of a rectangle,  $ABCD$ , and a semicircle.  $AD$  is the diameter of the semicircle.

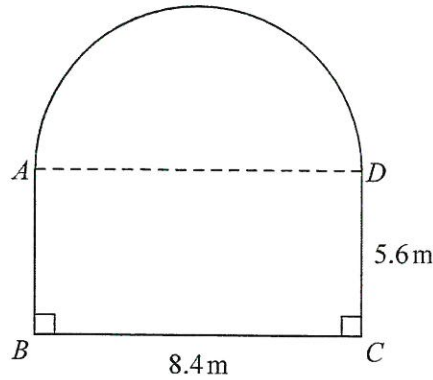

Carol is going to cover the garden with fertiliser.

A box of fertiliser costs £4.99

Carol has been told that one box of fertiliser will cover  $12\text{m}^2$  of garden.

- (a) Work out the cost of buying enough fertiliser to cover the garden completely.

$$\text{AREA OF } ABCD = 8.4 \times 5.6 = 47.04\text{m}^2$$

$$\text{AREA OF SEMI-CIRCLE} = \frac{1}{2} \pi \times 4.2^2 = 27.71\text{m}^2$$

$$\therefore \text{TOTAL AREA} = 47.04 + 27.71 = 74.75\text{m}^2$$

$$\frac{74.75}{12} = 6.23 \therefore \text{REQUIRE 7 BOXES}$$

$$7 \times £4.99 = £34.93$$

£ 34.93  
(5)

Carol finds out that one box of fertiliser will cover more than  $12\text{m}^2$  of garden.

- (b) Explain how this might affect the number of boxes she needs to buy.

NEEDS FEWER BOXES (PERHAPS - DEPENDS  
WHETHER NUMBER OF BOXES GOES BELOW 6)

(1)

(Total for Question 7 is 6 marks)



8 Sameena has a round pencil case and a square pencil case.

There are 4 blue pens and 3 red pens in the round pencil case. 7

There are 3 blue pens and 5 red pens in the square pencil case. 3

Sameena takes at random one pen out of each pencil case.

(a) Complete the probability tree diagram.

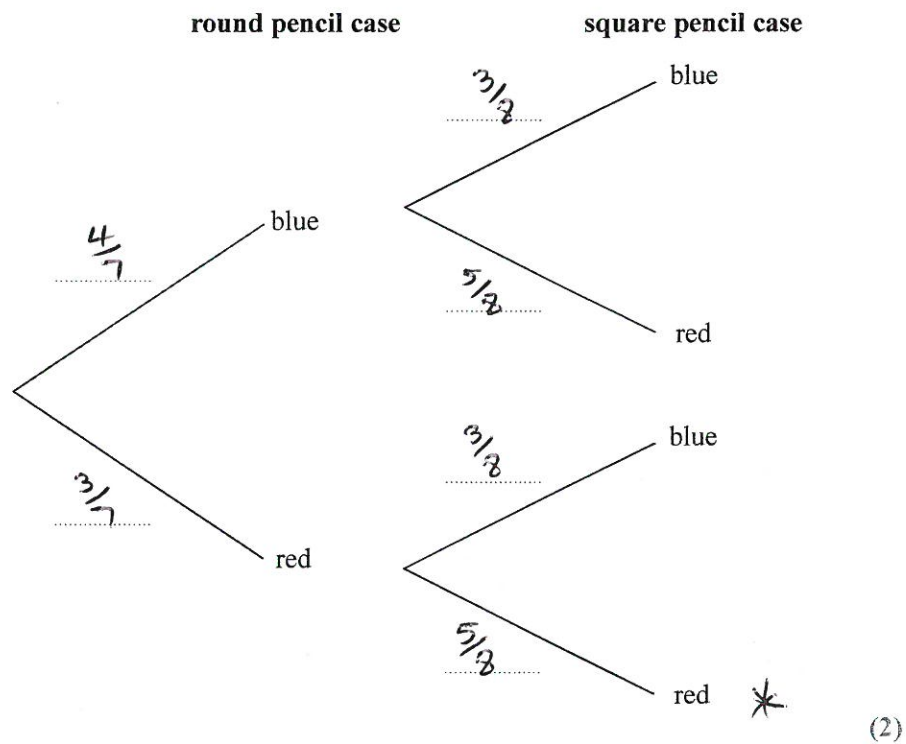

(b) Work out the probability that the pens Sameena takes are both red.

$$\frac{3}{7} \times \frac{5}{8} = \frac{15}{56}$$

$$\frac{15}{56}$$

(2)

(Total for Question 8 is 4 marks)





DO NOT WRITE IN THIS AREA

DO NOT WRITE IN THIS AREA

DO NOT WRITE IN THIS AREA

9 Here are six graphs.

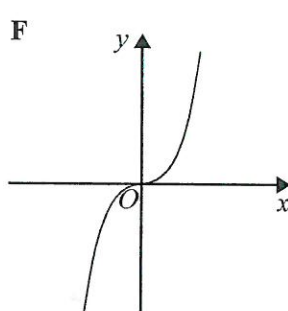
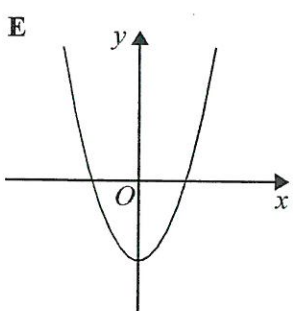
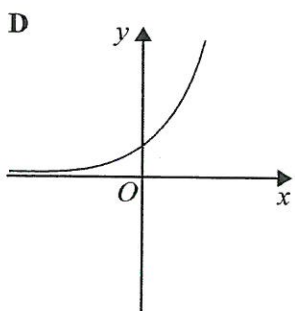
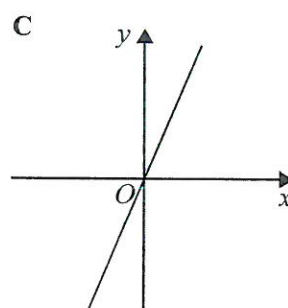
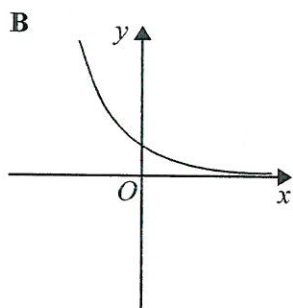
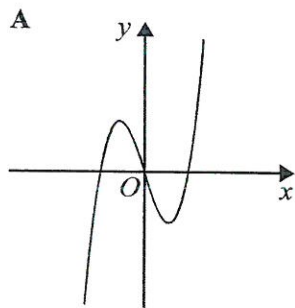

Write down the letter of the graph that could have the equation

(i)  $y = 2^x$

D

(ii)  $y = x^3 - 3x$

A

(Total for Question 9 is 2 marks)

10 Simplify  $3m^2r \times 4m^3r^6$

$12m^5r^7$

(Total for Question 10 is 2 marks)



11 Tom grows tomatoes.

The box plot below shows the distribution of the weights of 15 of Tom's tomatoes.

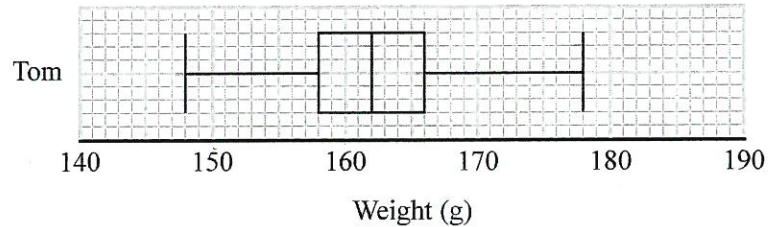

(a) Work out the interquartile range.

$$166 - 158 = 8$$

8 g  
(1)

Jack also grows tomatoes.

Here are the weights, in grams, of 15 of Jack's tomatoes.

153 155 158 164 166 167 170 170 173 174 175 175 177 179 186

(b) On the grid below, draw a box plot for this information.

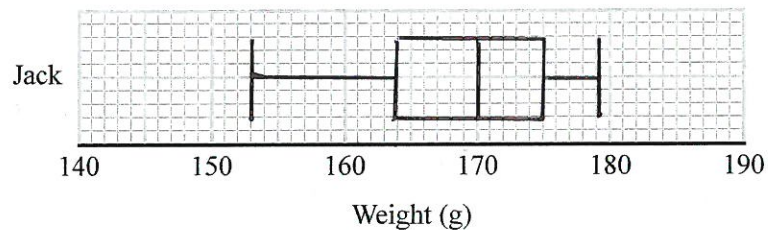

(3)

(c) Compare the distribution of the weights of Tom's tomatoes with the distribution of the weights of Jack's tomatoes.

JACK'S MEDIAN (170) IS HIGHER THAN TOM'S MEDIAN (162).

JACK'S IQR (11) IS HIGHER THAN TOM'S IQR (8).

TOM'S TOMATOES ARE A MORE CONSISTENT HEIGHT.

(2)

(Total for Question 11 is 6 marks)



12 The diagram shows a piece of wood in the shape of a cuboid.

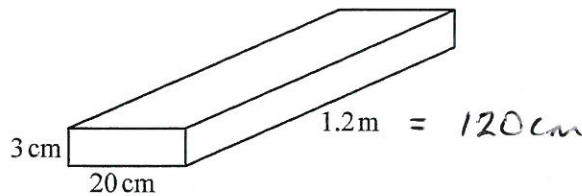

The piece of wood is 3 cm by 20 cm by 1.2 m.

The mass of the piece of wood is 8 kg. = 8000g

The piece of wood will float in sea water if the density of the wood is less than the density of the sea water.

In a large pool, 1 litre of sea water has a mass of 1030 g.

Will the piece of wood float in this pool?

You must show how you get your answer.

$$\text{VOLUME OF WOOD} = 3 \times 20 \times 120 = 7200 \text{ cm}^3$$

$$\text{DENSITY OF WOOD} = \frac{\text{MASS}}{\text{VOLUME}} = \frac{8000}{7200} = 1.11 \text{ g/cm}^3$$

$$1 \text{ LITRE} = 1000 \text{ cm}^3$$

$$\therefore \text{DENSITY OF SEA WATER} = \frac{1030}{1000} = 1.03 \text{ g/cm}^3$$

SINCE DENSITY OF WOOD > DENSITY OF SEA WATER  
THE PIECE OF WOOD WILL NOT FLOAT

(Total for Question 12 is 4 marks)



S 5 2 6 2 8 A 0 1 1 2 0

13 (a) Show that the equation  $x^3 + 5x - 4 = 0$  has a solution between  $x = 0$  and  $x = 1$

$$x = 0 \quad y = x^3 + 5x - 4 = -4$$

$$x = 1 \quad y = x^3 + 5x - 4 = 1 + 5 - 4 = 2$$

CHANGES FROM NEGATIVE TO POSITIVE  $\therefore$  MUST BE ZERO BETWEEN  $x = 0$  AND  $x = 1$ , ie HAS A SOLUTION (2)

(b) Show that the equation  $x^3 + 5x - 4 = 0$  can be arranged to give  $x = \frac{4}{x^2 + 5}$

$$x^3 + 5x - 4 = 0$$

$$\therefore x^3 + 5x = 4$$

$$\therefore x(x^2 + 5) = 4$$

$$\therefore x = \frac{4}{x^2 + 5}$$

(2)

(c) Starting with  $x_0 = 0$ , use the iteration formula  $x_{n+1} = \frac{4}{x_n^2 + 5}$  twice,

to find an estimate for the solution of  $x^3 + 5x - 4 = 0$

$$x_1 = \frac{4}{x_0^2 + 5} = \frac{4}{5}$$

$$x_2 = \frac{4}{x_1^2 + 5} = \frac{4}{\left(\frac{4}{5}\right)^2 + 5} = \frac{4}{\frac{16}{25} + 5} = \frac{4}{\frac{141}{25}} = \frac{100}{141} \approx 0.709$$

$$\frac{100}{141} \approx 0.709$$

(3)

(Total for Question 13 is 7 marks)



DO NOT WRITE IN THIS AREA

DO NOT WRITE IN THIS AREA

DO NOT WRITE IN THIS AREA

14 The number of fish in a lake decreases by  $x\%$  each year.

Given that the number of fish halves in 8 years, work out the value of  $x$ .  
Give your answer correct to 1 decimal place.

$$\text{NUMBER OF FISH AFTER 8 YEARS} = \left(1 - \frac{x}{100}\right)^8 \times \text{ORIGINAL NUMBER OF FISH}$$

$$\therefore \frac{1}{2} = \left(1 - \frac{x}{100}\right)^8$$

$$\therefore \left(\frac{1}{2}\right)^{\frac{1}{8}} = 1 - \frac{x}{100}$$

$$\therefore 0.917 = 1 - \frac{x}{100}$$

$$\therefore \frac{x}{100} = 1 - 0.917 = 0.083$$

$$\therefore x = 8.3\%$$

$$x = 8.3\%$$

(Total for Question 14 is 3 marks)

15 Here are two pots.

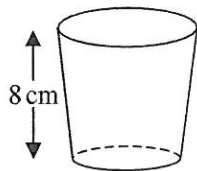

Pot A

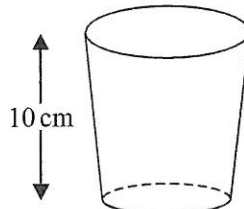

Pot B

Pot A and pot B are mathematically similar.

The area of the base of pot B is  $160 \text{ cm}^2$ .

Work out the area of the base of pot A.

$$\text{SCALE FACTOR FROM B TO A} = \frac{8}{10} = 0.8$$

$$\therefore \text{AREA S.F.} = 0.8^2 = 0.64$$

$$\therefore \text{AREA OF BASE OF POT A} = 0.64 \times 160$$

$$102.4 \text{ cm}^2$$

(Total for Question 15 is 2 marks)



S 5 2 6 2 8 A 0 1 3 2 0

16

$$v = \sqrt{\frac{a}{b}}$$

$a = 6.43$  correct to 2 decimal places.

$b = 5.514$  correct to 3 decimal places.

By considering bounds, work out the value of  $v$  to a suitable degree of accuracy.  
Give a reason for your answer.

$$\text{UPPER BOUND OF } A = 6.435$$

$$\text{LOWER BOUND OF } A = 6.425$$

$$\text{UPPER BOUND OF } B = 5.5145$$

$$\text{LOWER BOUND OF } B = 5.5135$$

$$\text{UPPER BOUND OF } v = \sqrt{\frac{6.435}{5.5135}} = 1.080340323$$

$$\text{LOWER BOUND OF } v = \sqrt{\frac{6.425}{5.5145}} = 1.079402689$$

UPPER AND LOWER BOUNDS OF  $v$  AGREE TO  
2 DECIMAL PLACES, ie UPPER BOUND = LOWER BOUND  
= 1.08 TO 2 D.P.

1.08

(Total for Question 16 is 5 marks)

14



S 5 2 6 2 8 A 0 1 4 2 0

DO NOT WRITE IN THIS AREA

DO NOT WRITE IN THIS AREA

DO NOT WRITE IN THIS AREA

17 The diagram shows a solid metal cylinder.

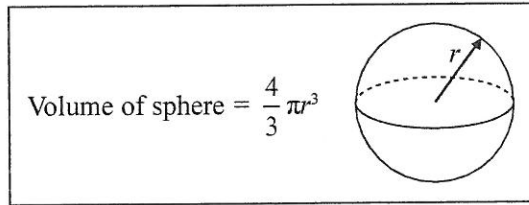
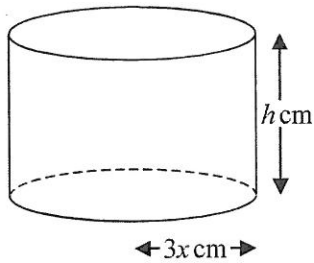

The cylinder has base radius  $3x$  cm and height  $h$  cm.

The metal cylinder is melted.

All the metal is then used to make 270 spheres.

Each sphere has a radius of  $\frac{1}{2}x$  cm.

Find an expression, in its simplest form, for  $h$  in terms of  $x$ .

$$\text{VOLUME OF CYLINDER} = \pi (3x)^2 h = 9\pi x^2 h$$

$$\begin{aligned} \text{VOLUME OF ONE SPHERE} &= \frac{4}{3}\pi \left(\frac{x}{2}\right)^3 = \frac{4\pi x^3}{3 \times 8} \\ &= \frac{\pi x^3}{6} \end{aligned}$$

$$\therefore 270 \times \frac{\pi x^3}{6} = 9\pi x^2 h$$

$$\therefore 5x^3 = x^2 h$$

$$\therefore 5x = h$$

$$h = 5x$$

(Total for Question 17 is 3 marks)



18 Make  $m$  the subject of

$$f = \frac{4-3m}{5+m}$$

$$f(5+m) = 4-3m$$

$$\therefore 5f + fm = 4-3m$$

$$\therefore fm + 3m = 4-5f$$

$$\therefore m(f+3) = 4-5f$$

$$\therefore m = \frac{4-5f}{f+3}$$

(Total for Question 18 is 4 marks)

DO NOT WRITE IN THIS AREA

DO NOT WRITE IN THIS AREA

DO NOT WRITE IN THIS AREA





DO NOT WRITE IN THIS AREA

DO NOT WRITE IN THIS AREA

DO NOT WRITE IN THIS AREA

19 The diagram shows a pyramid with base  $ABC$ .

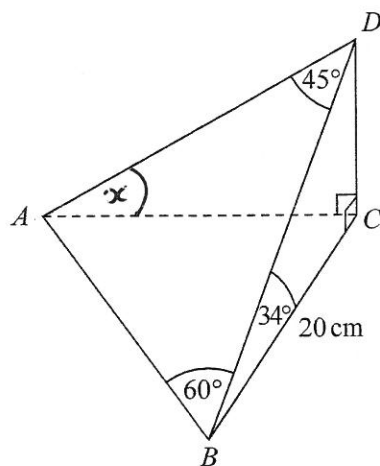

$CD$  is perpendicular to both  $CA$  and  $CB$ .

Angle  $CBD = 34^\circ$       Angle  $ADB = 45^\circ$       Angle  $DBA = 60^\circ$

$BC = 20$  cm.

Calculate the size of the angle between the line  $AD$  and the plane  $ABC$ . ie ANGLE  $x$   
Give your answer correct to 1 decimal place.

$$\cos 34 = \frac{20}{BD} \quad \therefore BD = \frac{20}{\cos 34} = 24.124 \text{ cm}$$

$$\hat{BAD} = 180 - 60 - 45 = 75^\circ$$

$$\therefore \text{USING SIN RULE} \quad \frac{24.124}{\sin 75} = \frac{AD}{\sin 60}$$

$$\therefore AD = 21.629$$

$$CD = \sqrt{24.124^2 - 20^2} = 13.490$$

$$\sin x = \frac{CD}{AD} = \frac{13.490}{21.629}$$

$$\therefore x = \sin^{-1} \left( \frac{13.490}{21.629} \right) \quad \underline{\quad 38.6 \quad}^\circ$$

(Total for Question 19 is 5 marks)



S 5 2 6 2 8 A 0 1 7 2 0

20 For all values of  $x$

$$f(x) = 2x - 3 \quad \text{and} \quad g(x) = x^2 + 2$$

(a) Find  $g(-4)$

$$(-4)^2 + 2 = 16 + 2 = 18$$

18

(1)

(b) Show that  $gf(x) = 4x^2 - 12x + 11$

$$\begin{aligned} gf(x) &= (2x - 3)^2 + 2 \\ &= 4x^2 - 12x + 9 + 2 \\ &= 4x^2 - 12x + 11 \end{aligned}$$

(2)

(c) Solve  $fg(x) = gf(x)$

$$\begin{aligned} fg(x) &= 2(x^2 + 2) - 3 \\ &= 2x^2 + 1 \end{aligned}$$

$$2x^2 + 1 = 4x^2 - 12x + 11$$

$$\therefore 2x^2 - 12x + 10 = 0$$

$$\therefore x^2 - 6x + 5 = 0$$

$$\therefore (x - 1)(x - 5) = 0$$

$$\therefore x = 1, 5$$

$x = 1, 5$

(4)

(Total for Question 20 is 7 marks)



21  $A, B, C$  and  $D$  are points on the circumference of a circle, centre  $O$ .

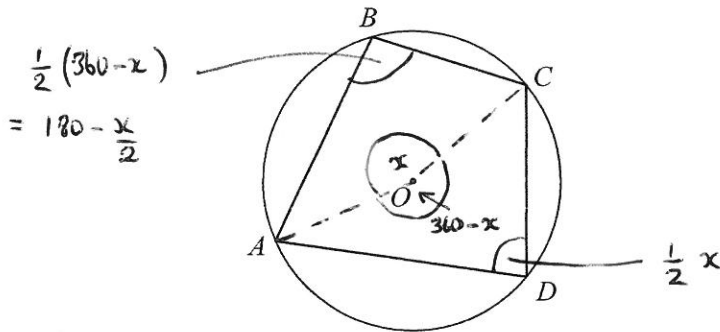

Prove that the sum of angle  $ABC$  and angle  $ADC$  is  $180^\circ$

$$\text{CALL } \hat{AOC} \text{ (OBTUSE)} = x$$

$$\therefore \hat{AOC} \text{ (REFLEX)} = 360 - x \quad \text{SINCE ANGLES AT A POINT ADD UP TO } 360^\circ$$

ANGLE AT CIRCUMFERENCE =  $\frac{1}{2}$  ANGLE AT CENTRE

$$\therefore \hat{ADC} = \frac{1}{2} x$$

$$\hat{ABC} = \frac{1}{2} (360 - x) = 180 - \frac{1}{2} x$$

$$\begin{aligned} \therefore \hat{ABC} + \hat{ADC} &= 180 - \frac{1}{2} x + \frac{1}{2} x \\ &= 180^\circ \end{aligned}$$

Q.E.D.

(Total for Question 21 is 4 marks)

TOTAL FOR PAPER IS 80 MARKS



DO NOT WRITE IN THIS AREA

DO NOT WRITE IN THIS AREA

DO NOT WRITE IN THIS AREA

BLANK PAGE

