

Write your name here					
Surname			Other names		
Centre Number			Candidate Number		
Pearson Edexcel Level 1/Level 2 GCSE (9 - 1)					
<h1 style="margin: 0;">Mathematics</h1> <h2 style="margin: 0;">Paper 1 (Non-Calculator)</h2>					
Higher Tier					
Mock Set 2 – Spring 2017			Paper Reference		
Time: 1 hour 30 minutes			1MA1/1H		
You must have: Ruler graduated in centimetres and millimetres, protractor, pair of compasses, pen, HB pencil, eraser. Tracing paper may be used.					Total Marks

Instructions

- Use **black** ink or ball-point pen.
- **Fill in the boxes** at the top of this page with your name, centre number and candidate number.
- Answer ALL questions.
- Answer the questions in the spaces provided – *there may be more space than you need.*
- **Calculators may not be used.**
- Diagrams are **NOT** accurately drawn, unless otherwise indicated.
- You must **show all your working out.**



Information

- The total mark for this paper is 80.
- The marks for **each** question are shown in brackets – *use this as a guide as to how much time to spend on each question.*

Advice

- Read each question carefully before you start to answer it.
- Keep an eye on the time.
- Try to answer every question.
- Check your answers if you have time at the end.

Answer ALL questions.

Write your answers in the spaces provided.

You must write down all the stages in your working.

1. Ali and Beth divide £280 in the ratio 2 : 5
Work out how much each person gets.

$$\begin{array}{l} 2 : 5 \quad 7 \\ 80 : 200 \quad 220 \end{array} \left. \begin{array}{l} \\ \end{array} \right\} \times 40$$

Ali £ 80

Beth £ 200

(Total for Question 1 is 2 marks)

2.

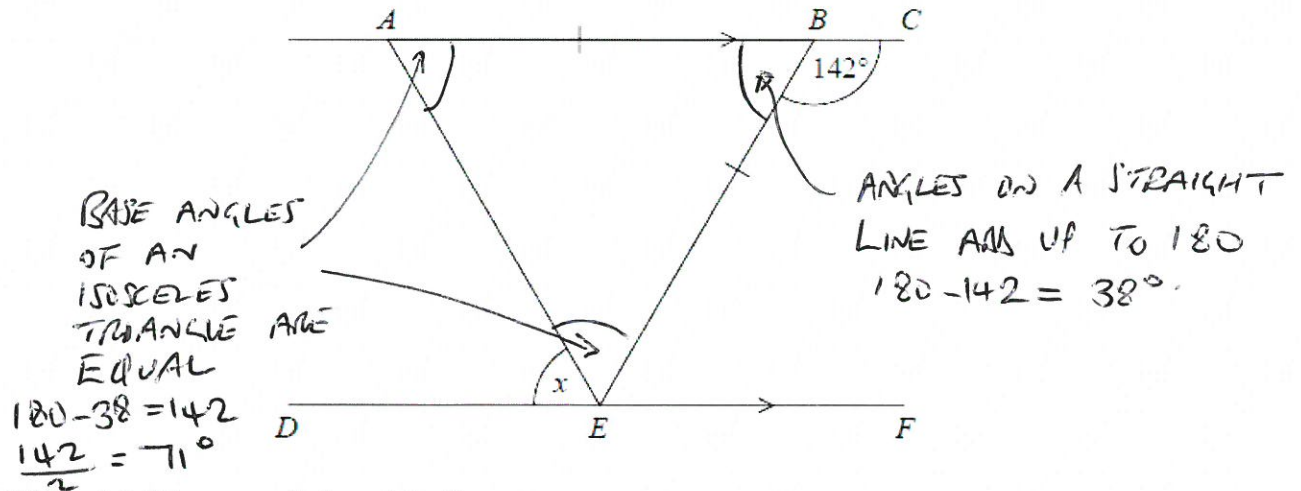

ABC and DEF are parallel straight lines.
 ABE is an isosceles triangle with $AB = BE$.
Angle $CBE = 142^\circ$

Work out the size of angle x .
Give a reason for each stage in your working.

$$\hat{BAE} = 71 \quad \text{ALTERNATE ANGLES ARE EQUAL}$$

$$\therefore x = 71^\circ$$

.....71.....^o

(Total for Question 2 is 5 marks)

3. The perimeter of a square has the same length as the perimeter of this triangle.

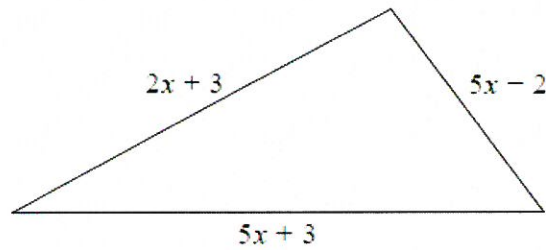

All measurements are in centimetres.

Find an expression, in terms of x , for the length of a side of the square.
Give your answer in its simplest form.

$$\begin{aligned}\text{PERIMETER OF TRIANGLE} &= 2x + 3 + 5x + 3 + 5x - 2 \\ &= 12x + 4\end{aligned}$$

$$\begin{aligned}\therefore \text{SIDE OF SQUARE} &= \frac{1}{4} (12x + 4) \\ &= 3x + 1\end{aligned}$$

$$\underline{\underline{3x + 1}}$$

(Total for Question 3 is 3 marks)

4.

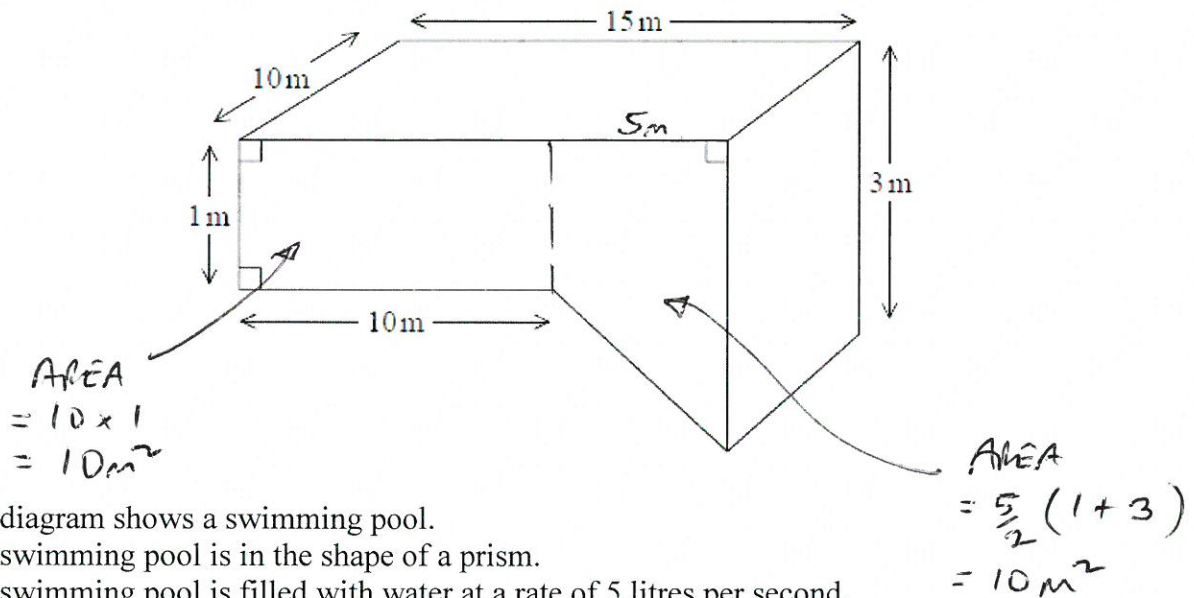

The diagram shows a swimming pool.
 The swimming pool is in the shape of a prism.
 The swimming pool is filled with water at a rate of 5 litres per second.

Jeremy has 10 hours to fill the swimming pool.
 $1 \text{ m}^3 = 1000 \text{ litres}$.

Will he completely fill the swimming pool in 10 hours?
 You must show all your working.

$$\text{AREA OF CROSS SECTION} = 10 + 10 = 20 \text{ m}^2$$

$$\therefore \text{VOLUME} = 20 \times 10 = 200 \text{ m}^3 = 200,000 \text{ LITRES}$$

$$\text{FILLS AT 5 LITRES / SECOND} \therefore \text{TAKES } \frac{200,000}{5} = 40,000 \text{ SECONDS}$$

$$1 \text{ HOUR} = 60 \times 60 = 3600 \text{ SECONDS}$$

$$\therefore \text{TAKES } \frac{40,000}{3600} \text{ HOURS} = \frac{400}{36} = \frac{100}{9} = 11 \frac{1}{9} \text{ HOURS}$$

JEREMY WILL NOT FILL THE POOL IN 10 HOURS.

(Total for Question 4 is 5 marks)

5. It takes 12 men 5 days to complete a job.

(a) Work out how many days it would take 3 men to complete the same job.

JOB TAKES $12 \times 5 = 60$ MAN DAYS

∴ FOR 3 MEN WILL TAKE $\frac{60}{3} = 20$ DAYS

..... 20
(2)

(b) (i) State one assumption you made in working out your answer.

3 MEN WORK AT THE SAME RATE AS 5 MEN

(ii) How will your answer be affected if your assumption is **not** correct?

NUMBER OF DAYS COULD INCREASE (OR DECREASE) IF RATE
IS SLOWER (OR HIGHER)

(2)

(Total for Question 5 is 4 marks)

6. Graham has a fair red 6-sided dice and a fair blue 8-sided dice.
 The red dice can land on 1, 2, 3, 4, 5 or 6
 The blue dice can land on 1, 2, 3, 4, 5, 6, 7 or 8

Graham is going to roll both dice.

- (a) Complete the probability tree diagram.

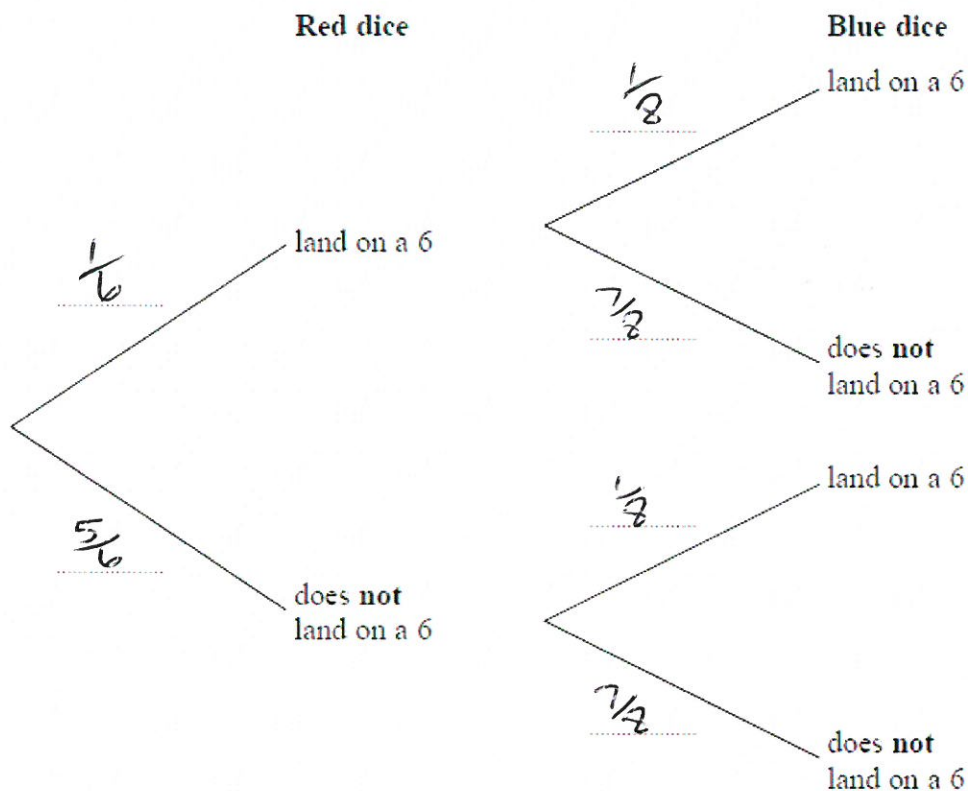

(2)

- (b) Work out the probability that neither dice will land on a 6

$$\frac{5}{6} \times \frac{7}{8}$$

$$\frac{35}{48}$$

(2)

(Total for Question 6 is 4 marks)

7. Here are the first 7 terms of a quadratic sequence.

3 6 11 18 27 38 51

+3 +5 +7 +9 +11 +13

(a) Find an expression, in terms of n , for the n th term in this sequence.

+2 +2 +2 +2 +2

$$T_n = an^2 + bn + c \quad \text{WITH } a = \frac{1}{2} \times 2 = 1$$

$$\therefore T_n - n^2 = bn + c$$

3 6 11 18

2 2 2 2

$$\therefore b = 0 \quad c = 2$$

$$\dots\dots\dots n^2 + 2 \dots\dots\dots (2)$$

(b) Find the 50th term of this sequence.

$$\begin{aligned} & 50^2 + 2 \\ &= 2500 + 2 \\ &= 2502 \end{aligned}$$

$$\dots\dots\dots 2502 \dots\dots\dots (1)$$

(Total for Question 7 is 3 marks)

8. Work out $2\frac{3}{4} \times 3\frac{1}{5}$

$$\frac{11}{4} \times \frac{16}{5} = \frac{44}{5} = 8\frac{4}{5}$$

$$\dots\dots\dots 8\frac{4}{5} \text{ (or } \frac{44}{5}) \dots\dots\dots$$

(Total for Question 8 is 2 marks)

9. 1 litre of a liquid **P** has a mass of p grams.
 1 litre of a liquid **Q** has a mass of q grams.

A liquid **R** is made by mixing a volume of liquid **P** with a volume of liquid **Q** in the ratio 3 : 7

Find an expression, in terms of p and q , for the mass of 50 litres of liquid **R**.

$$\begin{array}{l} 3 : 7 \quad 10 \\ 15 : 35 \quad 50 \downarrow \times 5 \end{array}$$

(or $5(3p+7q)$) $15p + 35q$ grams
 (Total for Question 9 is 3 marks)

10. Here are three rectangles.

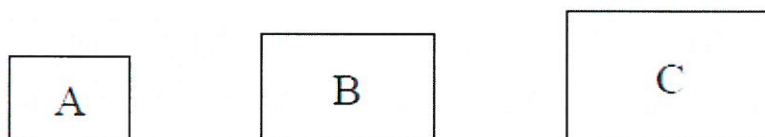

The area of rectangle **B** is 10% greater than the area of rectangle **A**.
 The area of rectangle **C** is 10% greater than the area of rectangle **B**.

By what percentage is the area of rectangle **C** greater than the area of rectangle **A**?

$$1.1 \times 1.1 = 1.21$$

..... 21

(Total for Question 10 is 3 marks)

11. The cumulative frequency table gives information about the time, in minutes, Jim took to go from his home to school each day last term.

Time taken (t minutes)	Cumulative frequency
$0 < t \leq 10$	0
$0 < t \leq 20$	7
$0 < t \leq 30$	20
$0 < t \leq 40$	64
$0 < t \leq 50$	74
$0 < t \leq 60$	80

- (a) On the grid opposite, draw a cumulative frequency graph for this information.

(2)

Jane expects that it should take her x minutes to go from her home to school each day. On 25% of the days last term, Jane took longer than x minutes to go from her home to school.

- (b) Use your cumulative frequency graph to find an estimate for the value of x .

$$25\% \text{ of } 80 = 20$$

$$80 - 20 = 60$$

$$\begin{array}{r} \dots\dots\dots 39 \dots\dots\dots \\ (37 - 39) \end{array} \quad (3)$$

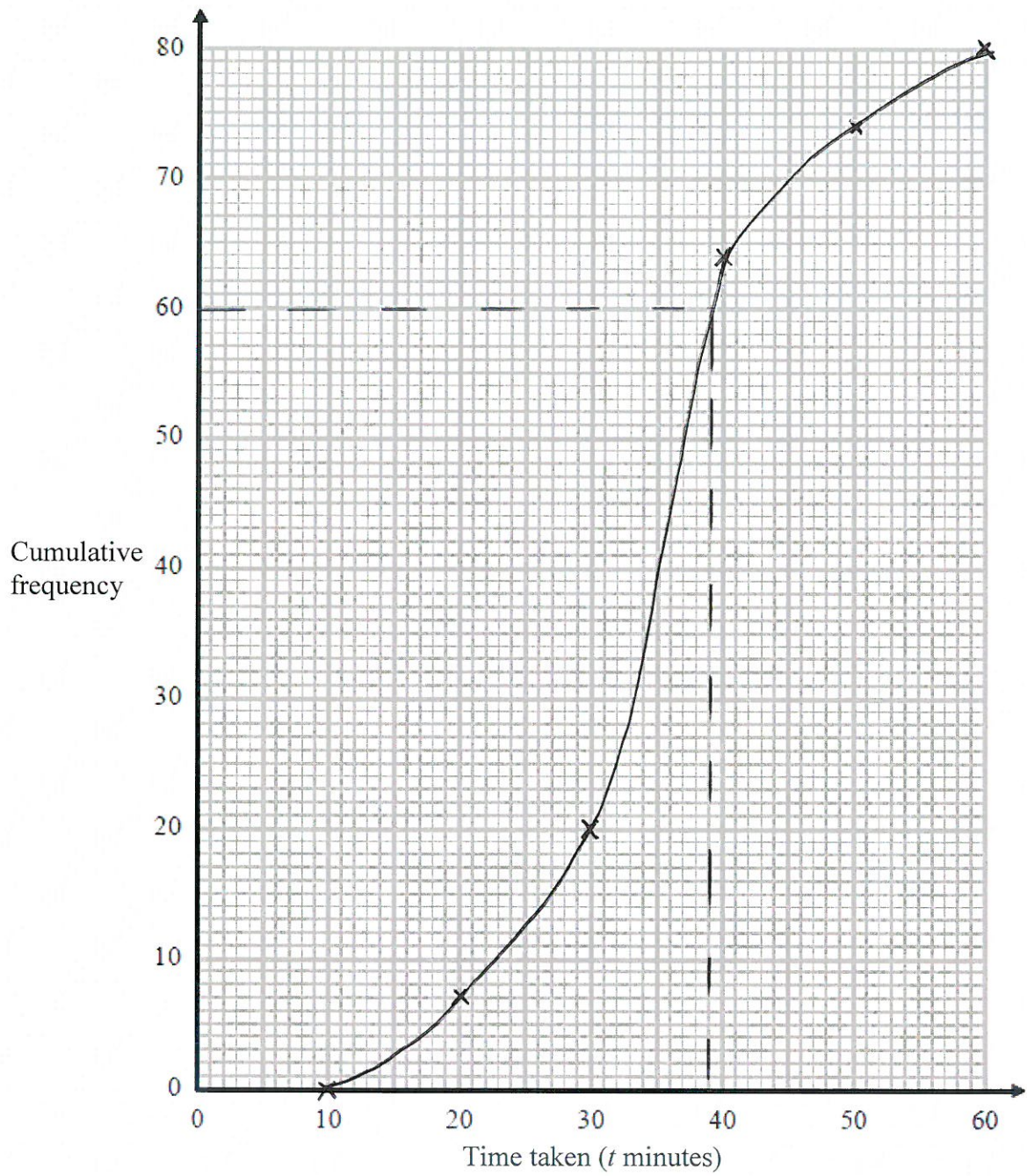

(Total for Question 11 is 5 marks)

12. Mark has 18 bags of counters and 12 boxes of counters.

The mean number of counters in all 30 bags and boxes is 14

The mean number of counters in the 18 bags is 10

Mark says

“The mean number of counters per box is 4”

Is Mark right?

You must show how you get your answer.

$$\text{NUMBER OF COUNTERS IN ALL BAGS AND BOXES} = 14 \times 30 = 420$$

$$\text{NUMBER OF COUNTERS IN BAGS} = 10 \times 18 = 180$$

$$\therefore \text{NUMBER OF COUNTERS IN BOXES} = 420 - 180 = 240.$$

$$\therefore \text{MEAN} = \frac{240}{12} = 20 \quad \text{SO MARK IS WRONG.}$$

(Total for Question 12 is 3 marks)

13. Prove that the recurring decimal $0.4\dot{3}$ has the value $\frac{13}{30}$

$$x = 0.4\dot{3}$$

$$\therefore 10x = 4.\dot{3}$$

$$\therefore 100x = 43.\dot{3}$$

$$\therefore 90x = 39$$

$$\therefore x = \frac{39}{90} = \frac{13}{30}$$

$$\div 3$$

(Total for Question 13 is 2 marks)

14. Jan has some metal that she is going to make into solid metal spheres.

Each sphere will have a radius of 2.15 cm. ≈ 2 cm

Jan has 1490 cm^3 of metal.

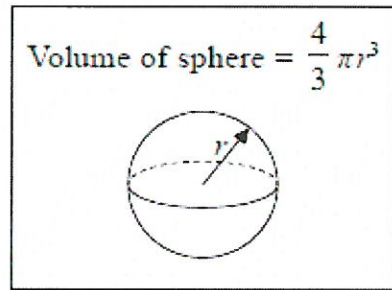

- (a) Work out an estimate for the number of spheres that Jan can make.

$$\text{VOLUME} = \frac{4}{3} \pi \times 2^3$$

$$\pi \approx 3 \quad \therefore \text{VOLUME} \approx 4 \times 8 = 32 \text{ cm}^3$$

$$\text{NUMBER OF SPHERES} \approx \frac{1500}{32} = 50$$

.....50.....
(3)

- (b) If you calculate the number of spheres accurately, how do you think your answer to part (a) will change?

Give a reason for your answer.

.....WOULD BE LESS SINCE RADIUS AND π HAVE BEEN ROUNDED
.....DOWN AND THEN '32' HAS BEEN ROUNDED DOWN WHILE 1490
.....HAS BEEN ROUNDED UP

(1)

(Total for Question 14 is 4 marks)

15. (a) Find the value of $\sqrt[4]{27 \times 3 \times 10^8}$

$$27 \times 3 = 81$$

$$\sqrt[4]{81} = 3$$

$$\frac{3 \times 10^2 \text{ or } 300}{(2)}$$

- (b) Find the value of $\left(\frac{216}{1000}\right)^{\frac{2}{3}}$

$$= \left(\frac{1000}{216}\right)^{\frac{2}{3}} = \left(\frac{10}{6}\right)^2$$

$$\frac{100}{36} \text{ (or } \frac{25}{9})$$

(2)

(Total for Question 15 is 4 marks)

16. Make t the subject of the formula $k = \frac{2(t+3)}{t-3}$

$$k(t-3) = 2(t+3)$$

$$kt - 3k = 2t + 6$$

$$kt - 2t = 3k + 6$$

$$t(k-2) = 3k+6$$

$$t = \frac{3k+6}{k-2}$$

$$t = \frac{3k+6}{k-2}$$

(Total for Question 16 is 4 marks)

17. (a) Factorise $3(x-y)^2 - 2(x-y)$

$$\begin{aligned} & (x-y) (3(x-y) - 2) \\ & = (x-y)(3x - 3y - 2) \end{aligned}$$

$$\frac{(x-y)(3x - 3y - 2)}{\dots\dots\dots} \quad (2)$$

(b) Show that $\frac{1}{2x^2+x-15} \div \frac{1}{3x^2+9x}$ simplifies to $\frac{ax}{bx+c}$ where a, b and c are integers.

$$2x^2 + x - 15 = (2x - 5)(x + 3)$$

$$3x^2 + 9x = 3x(x + 3)$$

$$\therefore \frac{3x^2 + 9x}{2x^2 + x - 15} = \frac{3x(x + 3)}{(2x - 5)(x + 3)} = \frac{3x}{2x - 5}$$

(3)

(Total for Question 17 is 5 marks)

18. Show that $\frac{4}{\frac{1}{\sqrt{3}} + \sqrt{3}}$ can be written as $\sqrt{3}$

$$\frac{1}{\sqrt{3}} = \frac{\sqrt{3}}{3} \quad \therefore \frac{1}{\sqrt{3}} + \sqrt{3} = \frac{\sqrt{3}}{3} + \sqrt{3} = \sqrt{3} \left(\frac{1}{3} + 1 \right)$$

$$= \frac{4\sqrt{3}}{3}$$

$$\therefore \frac{1}{\frac{1}{\sqrt{3}} + \sqrt{3}} = \frac{3}{4\sqrt{3}} = \frac{3}{4} \frac{\sqrt{3}}{\sqrt{3}} = \frac{\sqrt{3}}{4}$$

$$\therefore \frac{4}{\frac{1}{\sqrt{3}} + \sqrt{3}} = \frac{4\sqrt{3}}{4} = \sqrt{3}$$

(Total for Question 18 is 3 marks)

19. Prove that the sum of the squares of any three consecutive odd numbers is always 11 more than a multiple of 12.

LET THE 3 CONSECUTIVE ODD INTEGERS BE $2m+1, 2m+3, 2m+5$.

$$(2m+1)^2 = 4m^2 + 4m + 1$$

$$(2m+3)^2 = 4m^2 + 12m + 9$$

$$(2m+5)^2 = 4m^2 + 20m + 25$$

$$\therefore \text{SUM OF SQUARES} = 12m^2 + 36m + 35$$

$$= 12m^2 + 36m + 24 + 11$$

$$= \underbrace{12(m^2 + 3m + 2)}_{\text{MULTIPLE OF 12}} + \underbrace{11}_{\text{11 MORE}}$$

Q.E.D

(Total for Question 19 is 3 marks)

20.

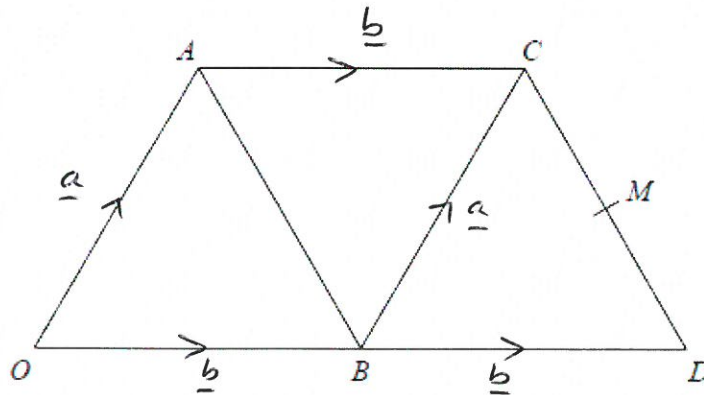

$OACD$ is a trapezium and $OACB$ is a parallelogram. $\therefore AC = OB$ AND $OA = BC$
 B is the midpoint of OD . $\therefore \vec{AC} = \vec{OB} = \underline{b}$ $\therefore \vec{BC} = \vec{OA} = \underline{a}$
 M is the midpoint of CD .

$$\vec{OA} = \underline{a} \text{ and } \vec{OB} = \underline{b}$$

Given that $\vec{BM} = k \times \vec{OC}$ where k is a scalar,

use a vector method to find the value of k .

$$\vec{OC} = \vec{OA} + \vec{AC} = \underline{a} + \underline{b}$$

$$\vec{BM} = \vec{BC} + \vec{CM} = \underline{a} + \frac{1}{2} \vec{CD}$$

$$\vec{CD} = \vec{CB} + \vec{BD} = -\underline{a} + \underline{b}$$

$$\therefore \vec{BM} = \underline{a} + \frac{1}{2} (-\underline{a} + \underline{b})$$

$$= \underline{a} - \frac{1}{2} \underline{a} + \frac{1}{2} \underline{b}$$

$$= \frac{1}{2} \underline{a} + \frac{1}{2} \underline{b}$$

$$= \frac{1}{2} (\underline{a} + \underline{b})$$

$$\therefore \vec{BM} = \frac{1}{2} \vec{OC}$$

$$\therefore k = \frac{1}{2}$$

$\frac{1}{2}$

(Total for Question 20 is 3 marks)

21. The length of a rectangle is the same as the length of each side of a square.

The length of the rectangle is 4 cm more than 3 times the width of the rectangle.

The area of the square is 66 cm^2 more than the area of the rectangle.

Find the length and the width of the rectangle.

You must show all your working.

$$\text{LET WIDTH OF RECTANGLE} = x$$

$$\therefore \text{LENGTH OF RECTANGLE} = 3x + 4$$

$$\therefore \text{SIDE LENGTH OF SQUARE} = 3x + 4$$

$$\text{AREA OF RECTANGLE} = x(3x + 4)$$

$$\text{AREA OF SQUARE} = (3x + 4)^2$$

$$\therefore (3x + 4)^2 = x(3x + 4) + 66$$

$$\therefore 9x^2 + 24x + 16 = 3x^2 + 4x + 66$$

$$\therefore 6x^2 + 20x - 50 = 0$$

$$\therefore 3x^2 + 10x - 25 = 0$$

$$\therefore (3x - 5)(x + 5) = 0$$

$$\therefore x = \frac{5}{3} \text{ or } -5$$

$$\therefore x = \frac{5}{3} \text{ SINCE } x > 0,$$

$$\therefore 3x + 4 = 3 \times \frac{5}{3} + 4 = 5 + 4 = 9,$$

$$\text{WIDTH} = \frac{5}{3} \text{ cm} \quad \text{LENGTH} = 9 \text{ cm}$$

(Total for Question 21 is 6 marks)

22. The diagram shows a quadrilateral $XYBA$.

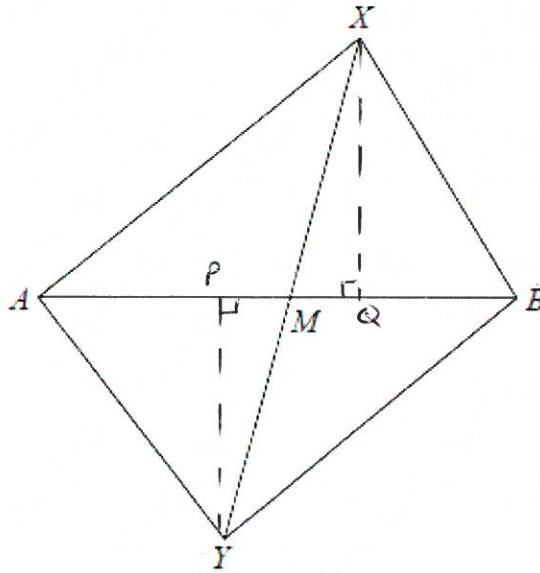

The diagonals AB and XY intersect at the point M .

Given that the area of triangle AXB is equal to the area of triangle AYB , prove that XY is bisected by AB .

$$\left. \begin{aligned} \text{AREA OF } \triangle X B &= \frac{1}{2} AB \cdot XQ \\ \text{AREA OF } \triangle Y B &= \frac{1}{2} AB \cdot YP \end{aligned} \right\} \begin{aligned} &\text{AREAS ARE EQUAL} \\ &\therefore XQ = YP \end{aligned}$$

$$\left. \begin{aligned} \sin \hat{A}M Y &= \frac{PY}{MY} \\ \sin \hat{B}M X &= \frac{XQ}{MX} \end{aligned} \right\} \begin{aligned} &\text{BUT } \hat{A}M Y = \hat{B}M X \text{ BECAUSE THEY ARE VERTICALLY} \\ &\hspace{10em} \text{OPPOSITE} \\ &\therefore \frac{YP}{MY} = \frac{XQ}{MX} \end{aligned}$$

$$\text{AND SINCE } YP = XQ, \quad MY = MX$$

$\therefore XY$ IS BISECTED BY AB .

(Total for Question 22 is 4 marks)

TOTAL FOR PAPER IS 80 MARKS

BLANK PAGE