

# GCSE Mathematics Practice Tests: Set 1

## Paper 1H (Non-calculator)

Time: 1 hour 30 minutes

You should have: Ruler graduated in centimetres and millimetres, protractor, pair of compasses, pen, HB pencil, eraser.

### Instructions

- Use **black** ink or ball-point pen.
- **Fill in the boxes** at the top of this page with your name, centre number and candidate number.
- Answer **all** questions.
- Answer the questions in the spaces provided – *there may be more space than you need.*
- **Calculators must not be used.**
- Diagrams are NOT accurately drawn, unless otherwise indicated.
- You must **show all your working out.**



### Information

- The total mark for this paper is 80
- The marks for **each** question are shown in brackets – *use this as a guide as to how much time to spend on each question.*

### Advice

- Read each question carefully before you start to answer it.
- Keep an eye on the time.
- Try to answer every question.
- Check your answers if you have time at the end.

Answer ALL questions.

Write your answers in the spaces provided.

You must write down all the stages in your working.

1. Work out  $5.4 \times 0.24$

$$\begin{array}{r} 54 \\ \times 24 \\ \hline 216 \\ 1080 \\ \hline 1296 \end{array}$$

.....1.296.....

(Total 3 marks)

---

2. The height,  $H$  cm, of a table is measured as 72 cm correct to the nearest centimetre.

Complete the following statement to show the range of possible values of  $H$ .

$$\dots 71.5 \dots \leq H < \dots 72.5 \dots$$

(Total 2 marks)

---

3. Jane has a carton of orange juice.  
The carton is in the shape of a cuboid.

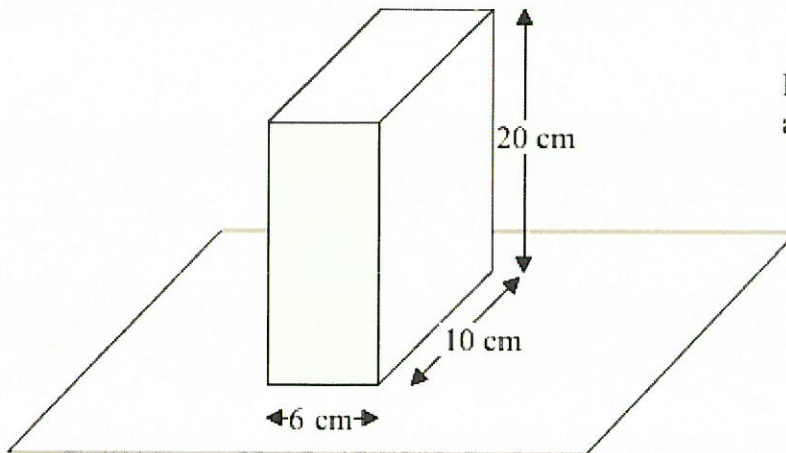

Diagram **NOT**  
accurately drawn

The depth of the orange juice in the carton is 8 cm.

Jane closes the carton.

Then she turns the carton over so that it stands on the shaded face.

Work out the depth, in cm, of the orange juice now.

$$\text{VOLUME OF O.J.} = 6 \times 10 \times 8 = 480 \text{ cm}^3$$

$$\therefore 6 \times 20 \times \text{DEPTH} = 480$$

$$\therefore \text{DEPTH} = \frac{480}{120} = 4 \text{ cm}$$

..... 4 ..... cm

(Total 3 marks)

4. Write the following numbers in order of size.  
Start with the smallest number.

$$0.038 \times 10^2 \quad 3800 \times 10^{-4} \quad 380 \quad 0.38 \times 10^{-1}$$

$$3 \cdot 8 \quad 0 \cdot 38 \quad 0 \cdot 038$$

.....  $0.38 \times 10^{-1}$  ,  $3800 \times 10^{-4}$  ,  $0.038 \times 10^2$  ,  $380$  .....

(Total 2 marks)

- 5.

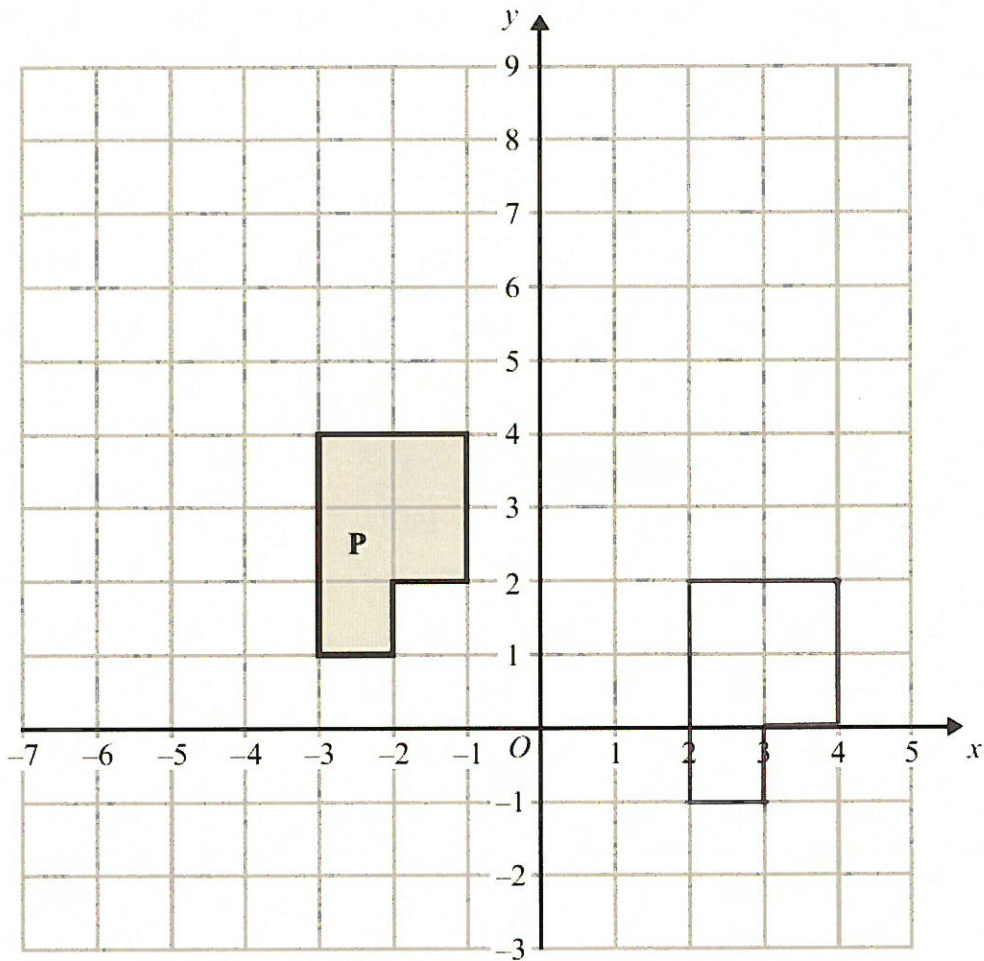

- (a) Translate shape P by the vector  $\begin{pmatrix} 5 \\ -2 \end{pmatrix}$ .

(2)

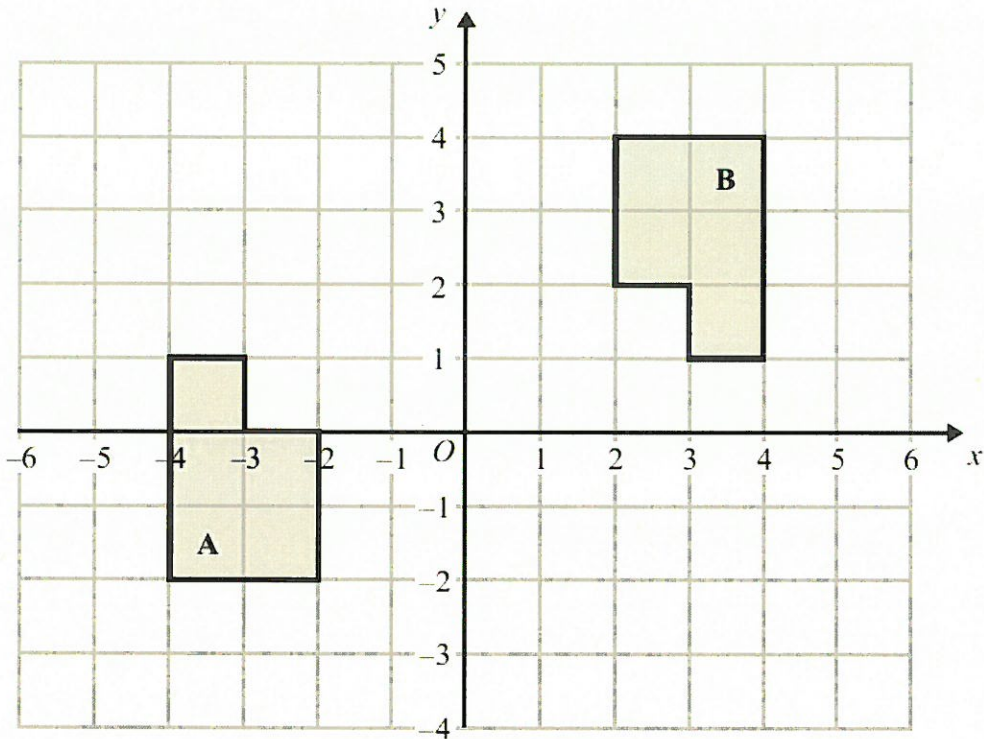

(b) Describe fully the single transformation that maps shape A onto shape B.

ROTATION  $180^\circ$  ABOUT  $(0, 1)$

(3)

(Total 5 marks)

6. (a) Simplify  $\frac{(x+2)^2}{x+2}$

$x+2$

(1)

(b) Simplify  $2a^2b \times 3a^3b$

$6a^5b^2$

(2)

(Total 3 marks)

7. Talil is going to make some concrete mix.  
He needs to mix cement, sand and gravel in the ratio 1 : 3 : 5 by weight.

Talil wants to make 180 kg of concrete mix.

Talil has

15 kg of cement

85 kg of sand

100 kg of gravel

Does Talil have enough cement, sand and gravel to make the concrete mix?

	C	S	G	
	1	3	5	9
NEEDS	20	60	100	180
HAS	15	85	100	

*Note: A handwritten arrow points from the '9' in the ratio row to the '180' in the 'NEEDS' row, with the label 'x 20' next to it.*

∴ DOESN'T HAVE ENOUGH CEMENT

(Total 4 marks)

8. Suha has a full 600 ml bottle of wallpaper remover.  
She is going to mix some of the wallpaper remover with water.

Here is the information on the label of the bottle.

**Wallpaper remover**  
600 ml  
Mix  $\frac{1}{4}$  of the wallpaper remover  
with 4500 ml of water

Suha is going to use 750 ml of water.

How many millilitres of wallpaper remover should Suha use?  
You must show your working.

$$\frac{4500}{750} = \frac{450}{75} = \frac{90}{15} = 6$$

150 ml OF REMOVER NEEDED FOR 4500ml OF WATER

$$\therefore \text{NEEDS } \frac{1}{6} \times 150 = 25 \text{ ml}$$

.....25.....ml

(Total 4 marks)

9. Sasha carried out a survey of 60 students.  
She asked them how many CDs they each have.

This table shows information about the numbers of CDs these students have.

Number of CDs	0 – 4	5 – 9	10 – 14	15 – 19	20 – 24
Frequency	8	11	9	14	18
	8	19	28	42	60

- (a) Write down the class interval containing the median.

.....15-19.....  
(1)

- (b) On the grid, draw a frequency polygon to show the information given in the table.

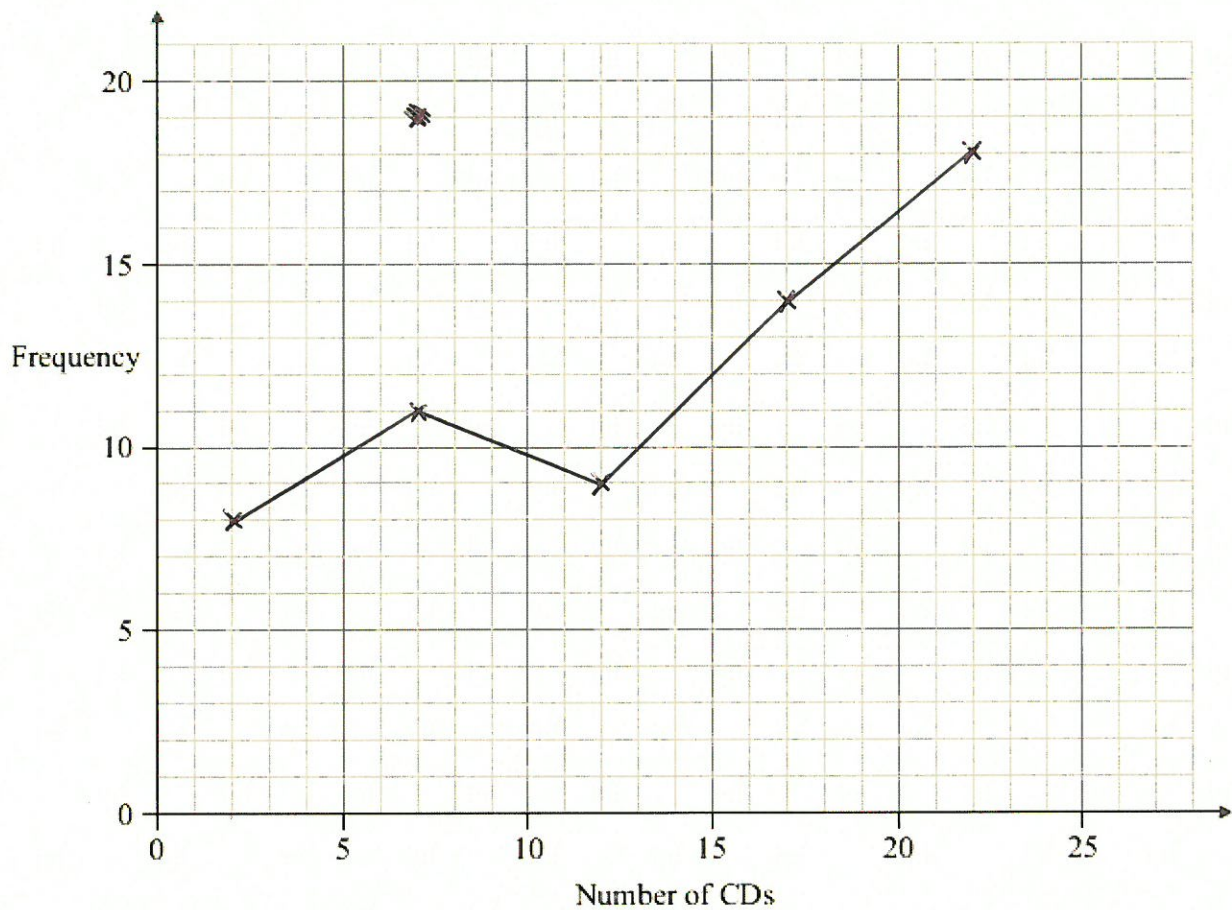

(2)

(Total 3 marks)



10. Make  $q$  the subject of the formula  $5(q + p) = 4 + 8p$   
Give your answer in its simplest form.

$$5q + 5p = 4 + 8p$$

$$5q = 4 + 3p$$

$$q = \frac{4 + 3p}{5}$$

$$q = \frac{4 + 3p}{5}$$

(Total 3 marks)

---

11. (a) Expand and simplify  $(x - 3)(x + 5)$

$$x^2 + 5x - 3x - 15$$

$$\underline{x^2 + 2x - 15} \quad (2)$$

- (b) Solve  $x^2 + 8x - 9 = 0$

$$(x + 9)(x - 1) = 0$$

$$\underline{x = -9, 1} \quad (3)$$

(Total 5 marks)

---

12. (a) Solve the inequality

$$3t + 1 < t + 12$$

$$2t < 11$$

$$t < \frac{11}{2}$$

$$\underline{t < \frac{11}{2}} \quad (2)$$

- (b)  $t$  is a whole number.  
Write down the largest value of  $t$  that satisfies

$$3t + 1 < t + 12$$

$$\frac{11}{2} = 5\frac{1}{2}$$

$$\underline{5} \quad (1)$$

(Total 3 marks)

---

13. The distance from Fulbeck to Ganby is 10 miles.  
The distance from Ganby to Horton is 18 miles.

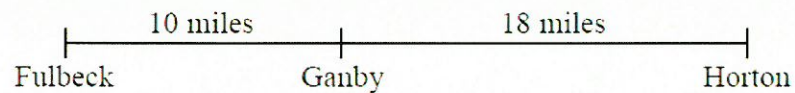

Raksha is going to drive from Fulbeck to Ganby.  
Then she will drive from Ganby to Horton.

Raksha leaves Fulbeck at 10 00.  
She drives from Fulbeck to Ganby at an average speed of 40mph.

Raksha wants to get to Horton at 10 35.

Work out the average speed Raksha must drive at from Ganby to Horton.

$F \rightarrow G$  : 10 MILES AT 40MPH  $\therefore$  TAKE  $\frac{1}{4}$  HR  
 $\therefore$  HAS 20 MINS FOR  $G \rightarrow H$  =  $\frac{1}{3}$  HR.  
 $\therefore$  MUST TRAVEL AT  $3 \times 18 = 54$  MPH.

.....54.....mph  
(Total 3 marks)

14.  $M$  is directly proportional to  $L^3$ .

When  $L = 2$ ,  $M = 160$

Find the value of  $M$  when  $L = 3$

$$M \propto L^3$$

$$\therefore M = kL^3$$

$$\therefore 160 = k \times 2^3 = 8k$$

$$\therefore k = 20$$

$$\therefore M = 20L^3$$

$$\begin{aligned} M &= 20 \times 3^3 \\ &= 20 \times 27 \\ &= 540 \end{aligned}$$

..... 540 .....

(Total 4 marks)

---

15. The incomplete histogram and table give some information about the distances some teachers travel to school.

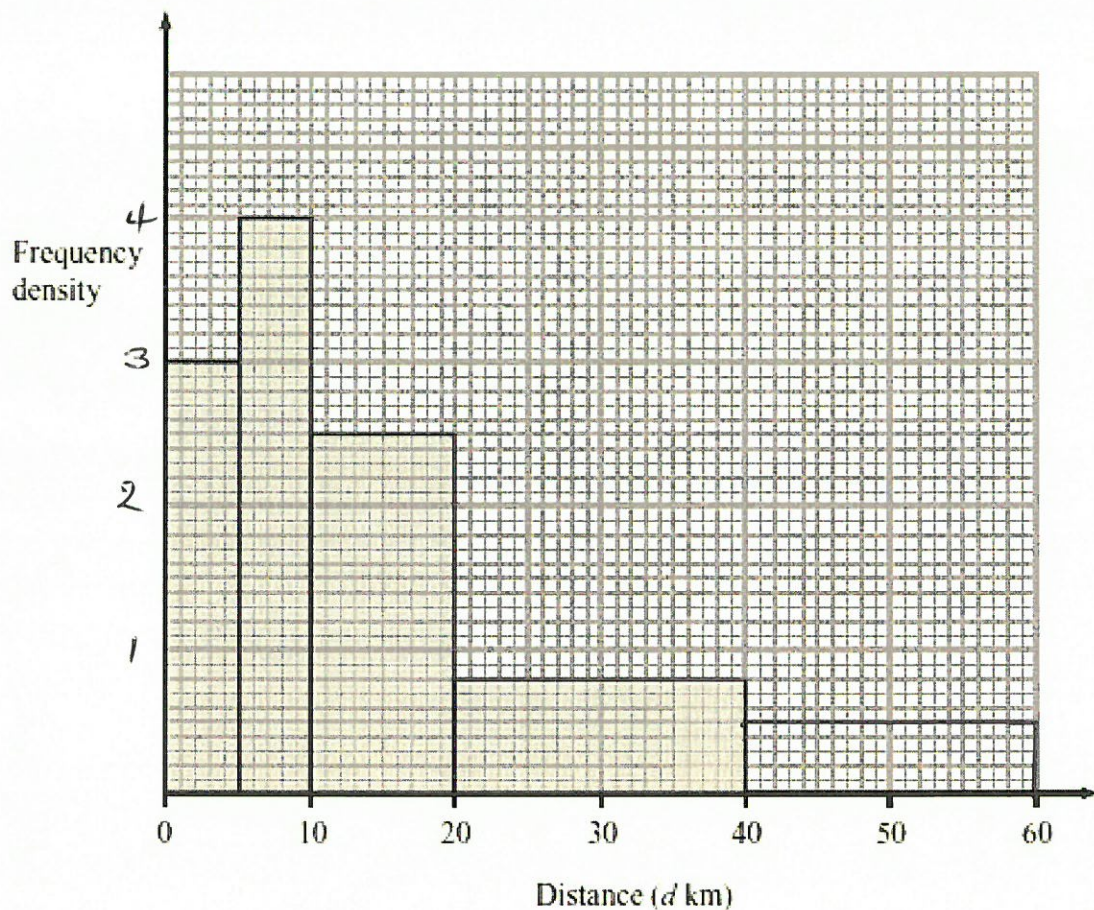

- (a) Use the information in the histogram to complete the frequency table.

Distance ( $d$ km)	Frequency
$0 < d \leq 5$	15
$5 < d \leq 10$	20
$10 < d \leq 20$	$2.5 \times 10 = 25$
$20 < d \leq 40$	$0.8 \times 20 = 16$
$40 < d \leq 60$	10

FREQUENCY  
DENSITY

$$15 \div 5 = 3$$

$$20 \div 5 = 4$$

$$2.5$$

$$0.8$$

$$10 \div 20 = 0.5$$

(2)

- (b) Use the information in the table to complete the histogram.

(1)

(Total 3 marks)

16. (a) Write down the value of  $49^{\frac{1}{2}}$

.....7.....  
(1)

(b) Write  $\sqrt{45}$  in the form  $k\sqrt{5}$ , where  $k$  is an integer.

$$\sqrt{9 \times 5} = 3\sqrt{5}$$

.....3\sqrt{5}.....  
(1)

(Total 2 marks)

---

17.  $x = 0.0\dot{4}5$

Prove algebraically that  $x$  can be written as  $\frac{1}{22}$

$$10x = 0.4\dot{5}$$

$$1000x = 45.4\dot{5}$$

$$990x = 45$$

$$x = \frac{45}{990} = \frac{5}{110} = \frac{1}{22}$$

(Total 3 marks)

---

18.

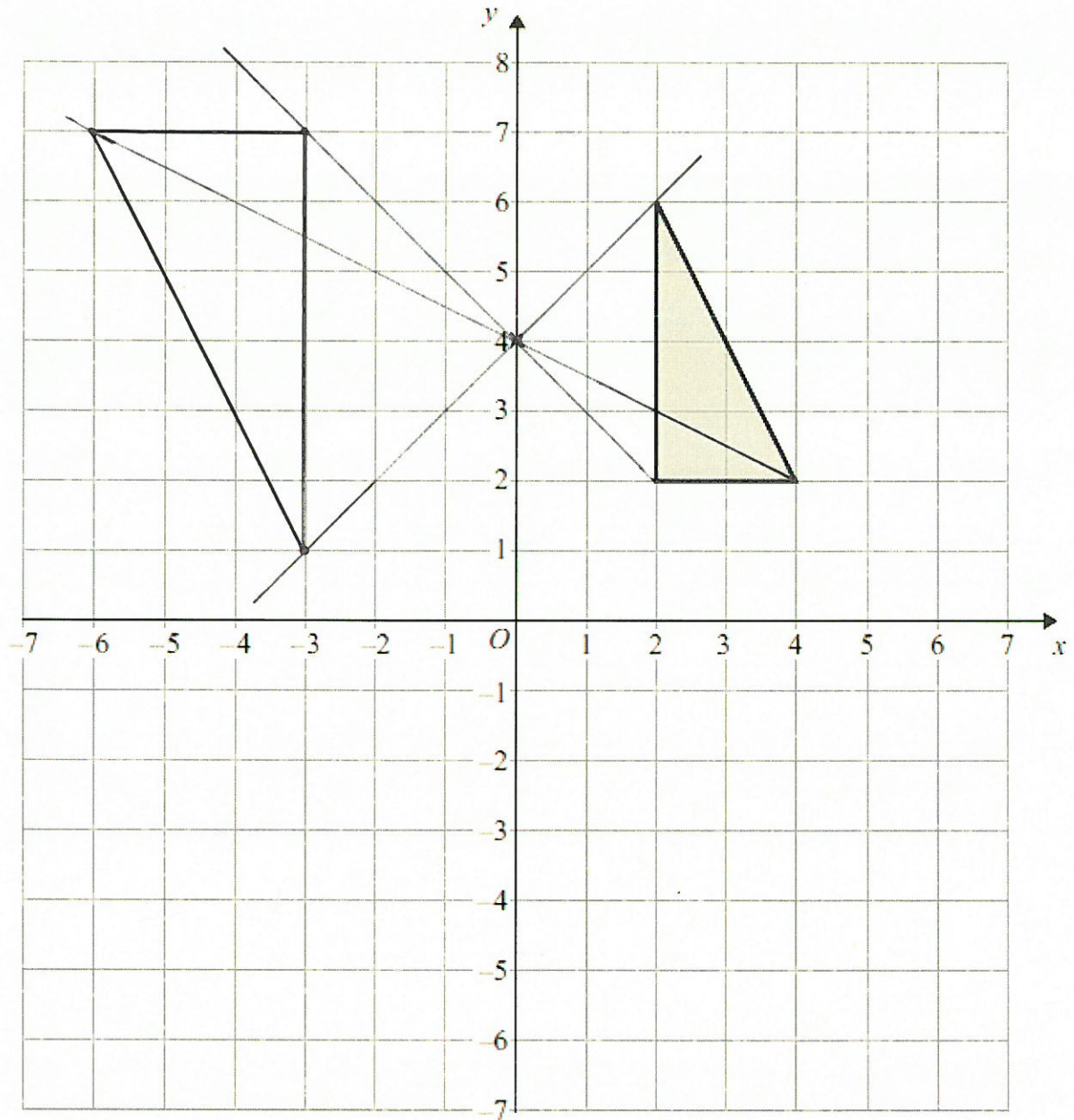

Enlarge the shaded shape by a scale factor of  $-1\frac{1}{2}$ , centre  $(0, 4)$ .

**(Total 3 marks)**

---

19. There are three different types of sandwiches on a shelf.

There are

4 egg sandwiches,  
5 cheese sandwiches  
and 2 ham sandwiches.

11

Erin takes at random 2 of these sandwiches.

Work out the probability that she takes 2 different types of sandwiches.

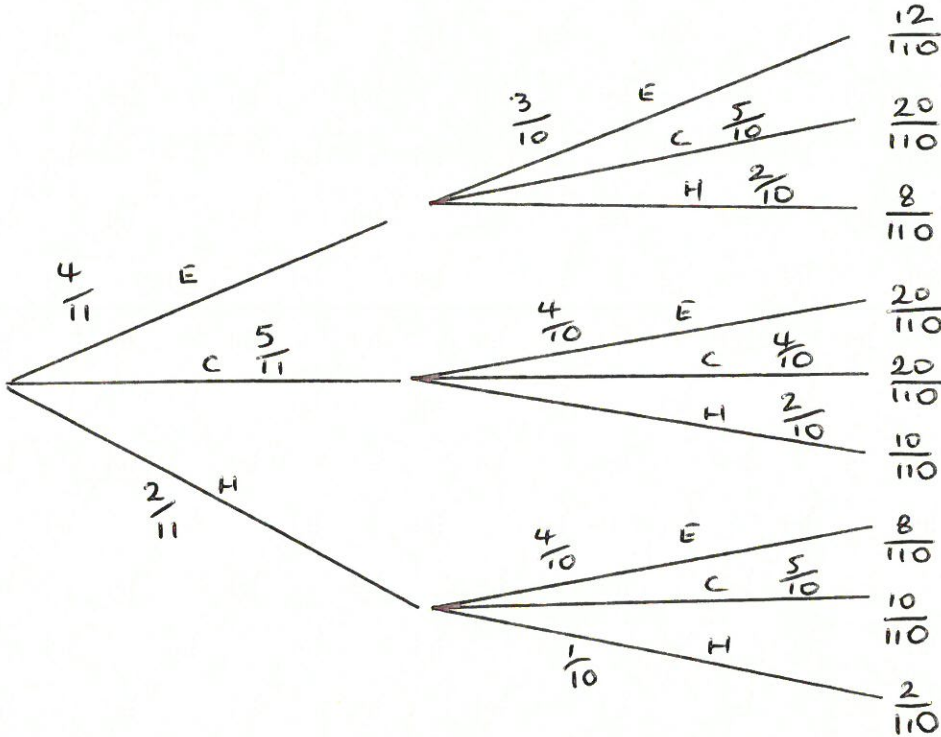

$$\frac{20}{110} + \frac{8}{110} + \frac{20}{110} + \frac{10}{110} + \frac{8}{110} + \frac{10}{110} = \frac{76}{110}$$

$$\frac{76}{110}$$

(Total 5 marks)



20.

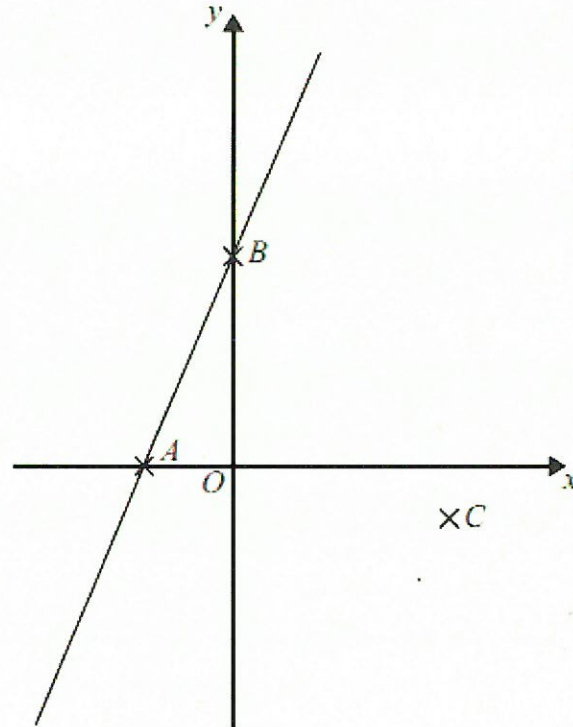

Diagram NOT  
accurately drawn

In the diagram

- A is the point  $(-2, 0)$
- B is the point  $(0, 4)$
- C is the point  $(5, -1)$

Find an equation of the line that passes through C and is perpendicular to AB.

$$\text{GRADIENT OF } AB = \frac{4-0}{0-(-2)} = \frac{4}{2} = 2$$

$$\therefore \text{GRADIENT OF PERPENDICULAR} = -\frac{1}{2}$$

$$\therefore \text{EQUATION OF PERPENDICULAR} = y = -\frac{1}{2}x + c$$

$$\text{AT } C \quad -1 = -\frac{1}{2} \times 5 + c$$

$$\therefore c = \frac{3}{2}$$

$$y = -\frac{1}{2}x + \frac{3}{2}$$

(Total 4 marks)

21. (a) Construct the graph of  $x^2 + y^2 = 9$  CIRCLE OF RADIUS  $\sqrt{9} = 3$

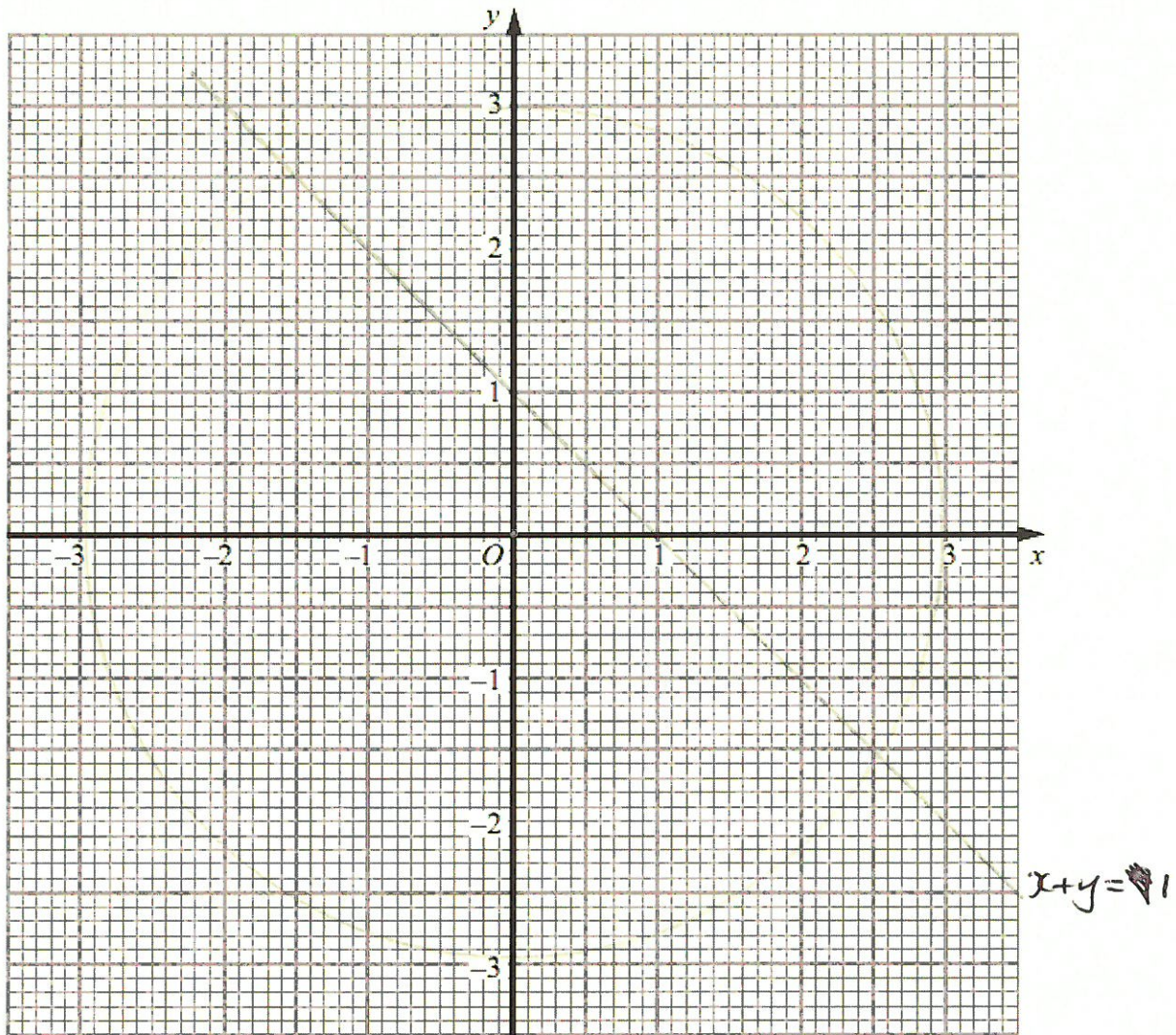

(2)

(b) By drawing the line  $x + y = 1$  on the grid, solve the equations  $x^2 + y^2 = 9$   
 $x + y = 1$

$$x = 2.6, y = -1.6$$

$$\text{or } x = -1.6, y = 2.6$$

(3)

(Total 5 marks)

22.

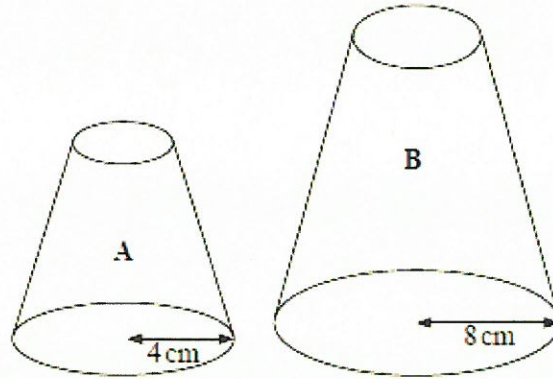

Two solid shapes, **A** and **B**, are mathematically similar.

The base of shape **A** is a circle with radius 4 cm.

The base of shape **B** is a circle with radius 8 cm.

The surface area of shape **A** is  $80 \text{ cm}^2$ .

(a) Work out the surface area of shape **B**.

$$\text{SCALE FACTOR} = \frac{8}{4} = 2$$

$$\therefore \text{AREA S.F.} = 2^2 = 4$$

$$4 \times 80 = 320$$

$$\dots\dots\dots 320 \dots\dots\dots \text{cm}^2$$

(2)

The volume of shape **B** is  $600 \text{ cm}^3$ .

(b) Work out the volume of shape **A**.

$$\text{VOLUME S.F.} = 2^3 = 8$$

$$\frac{600}{8} = 75$$

$$\dots\dots\dots 75 \dots\dots\dots \text{cm}^3$$

(2)

(Total 4 marks)

23.

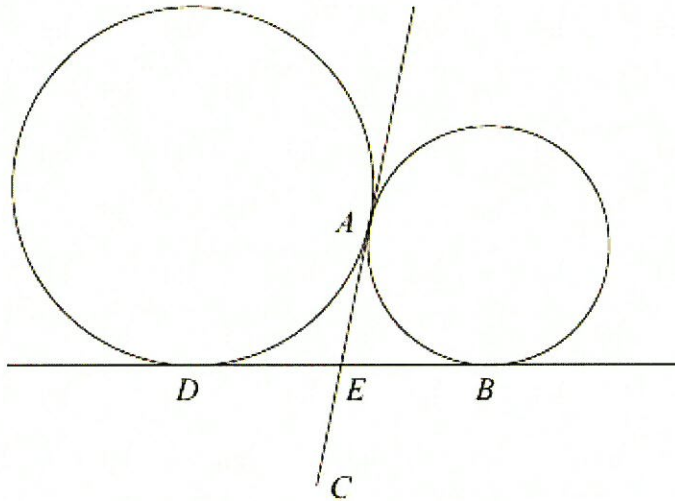

Diagram NOT  
accurately drawn.

$A$  and  $D$  are two points on the circumference of a circle.

$A$  and  $B$  are two points on the circumference of a smaller circle.

$DB$  and  $AC$  are tangents to both circles.

$E$  is the intersection of  $DB$  and  $AC$ .  $\rightarrow$  BUT IS IT THE MIDPOINT OF  $DB$ ?

$E$  is the midpoint of  $AC$ .

Prove that  $ABCD$  is a rectangle.

TANGENTS FROM A COMMON POINT ARE EQUAL IN LENGTH

$$\therefore EA = EB$$

$$EA = ED$$

$$\therefore EB = ED \therefore E \text{ IS THE MIDPOINT OF } DB$$

WE ARE TOLD THAT  $E$  IS THE MID-POINT OF  $AC$

$\therefore$  EACH DIAGONAL OF  $ABCD$  IS BISECTED

$\therefore$   $ABCD$  IS A RECTANGLE OR A SQUARE

(Total 4 marks)

---

TOTAL FOR PAPER IS 80 MARKS