

Please check the examination details below before entering your candidate information

Candidate surname

Other names

Centre Number

Candidate Number

Pearson Edexcel

Level 1/Level 2 GCSE (9–1)

**Tuesday 5 November 2019**

Morning (Time: 1 hour 30 minutes)

Paper Reference **1MA1/1F****Mathematics****Paper 1 (Non-Calculator)****Foundation Tier**

**You must have:** Ruler graduated in centimetres and millimetres, protractor, pair of compasses, pen, HB pencil, eraser. Tracing paper may be used.

Total Marks

**Instructions**

- Use **black** ink or ball-point pen.
- **Fill in the boxes** at the top of this page with your name, centre number and candidate number.
- Answer **all** questions.
- Answer the questions in the spaces provided – *there may be more space than you need.*
- You must **show all your working**.
- Diagrams are **NOT** accurately drawn, unless otherwise indicated.
- **Calculators may not be used.**

**Information**

- The total mark for this paper is 80
- The marks for **each** question are shown in brackets – *use this as a guide as to how much time to spend on each question.*

**Advice**

- Read each question carefully before you start to answer it.
- Keep an eye on the time.
- Try to answer every question.
- Check your answers if you have time at the end.

Turn over ►

P58865A

©2019 Pearson Education Ltd.

6/1/1/



P 5 8 8 6 5 A 0 1 2 0



Pearson

Answer ALL questions.

Write your answers in the spaces provided.

You must write down all the stages in your working.

1 Write down the value of the 7 in the number 1074

70

(Total for Question 1 is 1 mark)

2 Write 4.58 correct to 1 decimal place.

4.6

(Total for Question 2 is 1 mark)

3 Work out  $31.7 \times 100$

3170

(Total for Question 3 is 1 mark)

4 Write the fraction  $\frac{28}{70}$  in its simplest form.

$\div 7$   $\frac{4}{10}$   $\div 2$   $\frac{2}{5}$

$\frac{2}{5}$

(Total for Question 4 is 1 mark)

5 Write 15% as a decimal.



0.15

(Total for Question 5 is 1 mark)

DO NOT WRITE IN THIS AREA

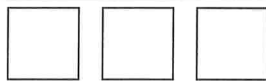
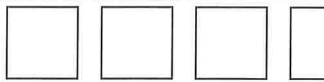
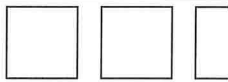

- 6 The pictogram shows information about the number of pictures sold in an art shop in each of January, February and March.

January	
February	
March	
April	

Key:



represents 8 pictures

- (a) Write down the number of pictures sold in January.

$$3 \times 8$$

24

(1)

12 pictures were sold in April.

- (b) Show this information on the pictogram.

(1)

- (c) What was the total number of pictures sold in these four months?

$$3 + 3\frac{1}{2} + 2\frac{1}{2} + 1\frac{1}{2}$$

$$= 10\frac{1}{2} = 10.5$$

$$10.5 \times 8$$

84

(2)

(Total for Question 6 is 4 marks)

- 7 Work out the difference, in minutes, between 1 hour 25 minutes and  $1\frac{1}{4}$  hours.

$$1\frac{1}{4} \text{ HOURS} = 1 \text{ HOUR } 15 \text{ MINUTES}$$

$$25 - 15 = 10$$

10

minutes

(Total for Question 7 is 2 marks)



8 Prasha has five blocks of wood.

The total weight of all five blocks of wood is 3 kilograms.  
4 of the blocks of wood each have a weight of 650 grams.

Work out the weight, in grams, of the other block of wood.

$$3 \text{ kg} = 3000 \text{ g}$$

$$4 \times 650 = 2600 \text{ g}$$

$$3000 - 2600 = 400.$$

..... 400 ..... grams

(Total for Question 8 is 3 marks)

9  $PQR$  is a straight line.

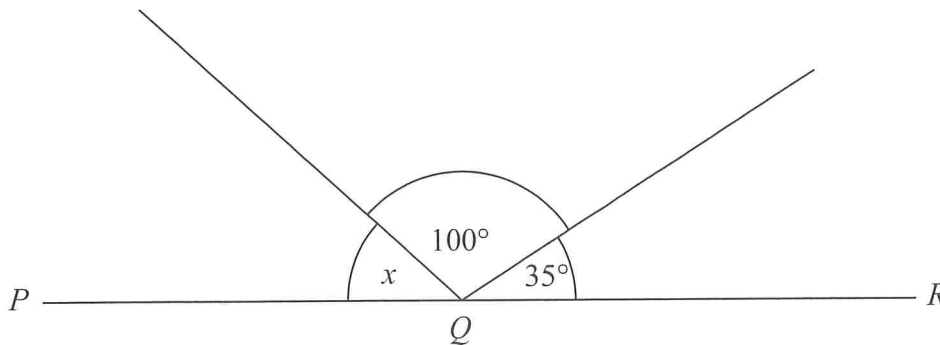

Work out the size of angle  $x$ .

$$180 - 100 - 35$$

..... 45 ..... °

(Total for Question 9 is 2 marks)



10

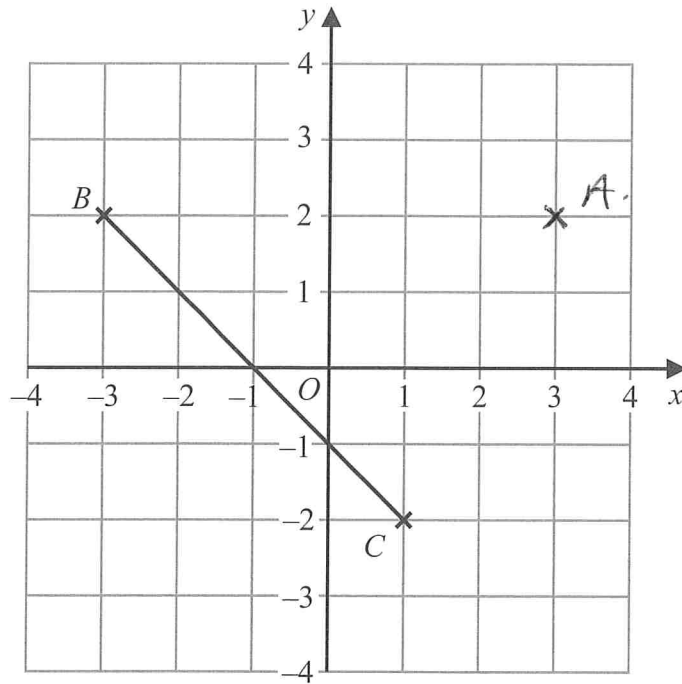

- (a) Plot the point with coordinates (3, 2)  
Label this point *A*.

(1)

- (b) Write down the coordinates of the midpoint of *BC*.

( -1 , 0 )  
(1)

(Total for Question 10 is 2 marks)

- 11 Mason throws a coin 3 times.  
The outcome of each throw is either Heads or Tails.

List all the possible outcomes of the 3 throws.

H H H    H H T    H T H    H T T

T H H    T H T    T T H    T T T

(Total for Question 11 is 2 marks)



DO NOT WRITE IN THIS AREA

12 Rehan is on holiday in the USA.

He has \$200 to spend on clothes.

Rehan buys

1 pair of trainers costing \$60

3 T-shirts costing \$25 each.

$$3 \times 25 = 75$$

He also wants to buy a jacket costing \$80

(a) Has Rehan got enough money to buy the jacket?

You must show how you get your answer.

$$75 + 60 = 135$$

$$200 - 135 = 65$$

REHAN HAS ONLY \$65 LEFT SO CANNOT  
BUY THE JACKET FOR \$80.

(3)

The trainers cost \$60

The exchange rate is \$1 = £0.749

Rehan says,

“The trainers cost less than £40”

Rehan is wrong.

(b) Using a suitable approximation, show working to explain why.

EXCHANGE RATE IS APPROX \$1 = £0.75

$$\therefore \$60 = \frac{3}{4} \times 60 = £45$$

AND £45 IS MORE THAN £40

(2)

(Total for Question 12 is 5 marks)



13 (a) Simplify  $2a \times 5b$

$$\frac{10ab}{(1)}$$

(b) Simplify  $3x + 2y + 5x - y$

$$3x + 2y + 5x - y$$

$$\frac{8x + y}{(2)}$$

(Total for Question 13 is 3 marks)

14 Work out  $23 \times 15$

$$\begin{array}{r} 23 \\ \times 15 \\ \hline 115 \\ 230 \\ \hline 345 \end{array}$$

$$\frac{345}{(2)}$$

(Total for Question 14 is 2 marks)



15 120 people were at a hockey match.

Each person was asked if they wanted to stand or to sit to watch the match.

- 75 of the people were female
- 29 of the males wanted to stand
- 30 of the people wanted to sit

(a) Use this information to complete the frequency tree.

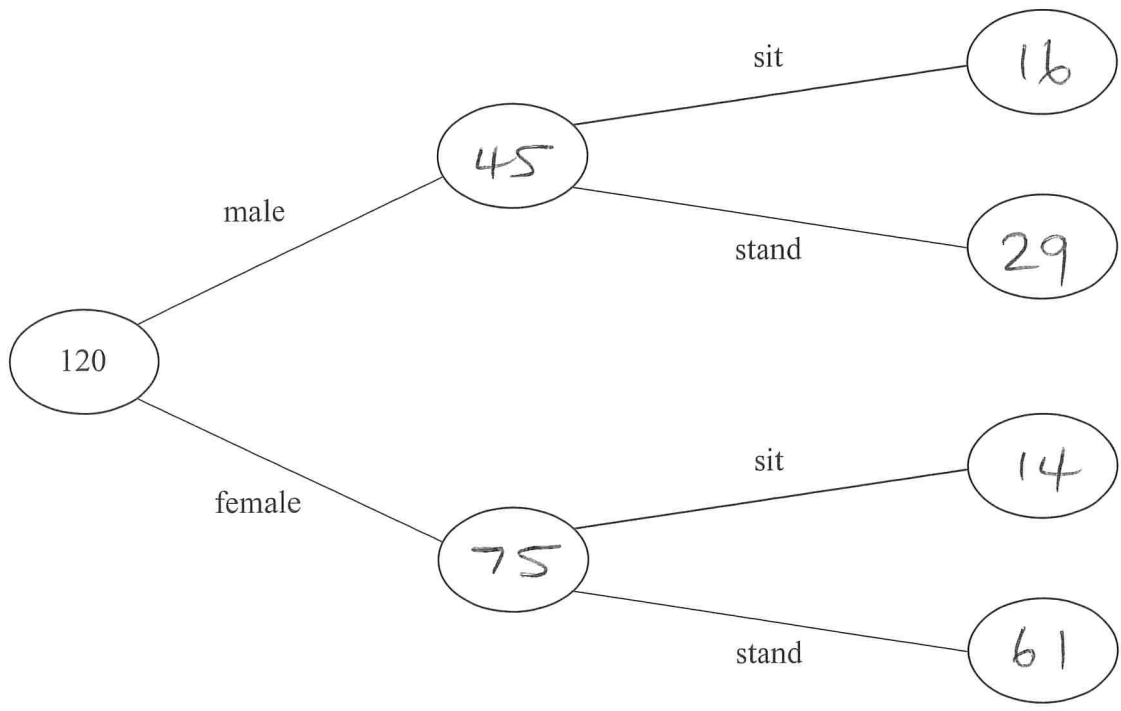

(3)

One of the 120 people is chosen at random.

(b) Write down the probability that this person is a male who wanted to stand.

$$\frac{29}{120}$$

(1)

(Total for Question 15 is 4 marks)





- 16 Steve drove from his home to his friend's house.  
He stayed at his friend's house and then drove home.

Here is Steve's travel graph.

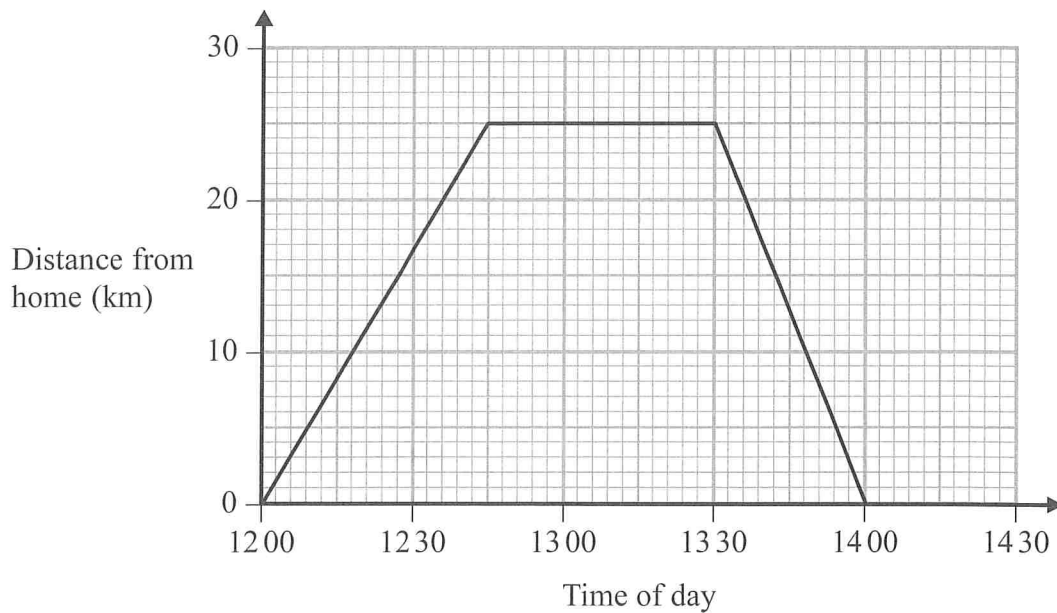

- (a) For how many minutes did Steve stay at his friend's house?

12:45 → 13:30

..... 45 ..... minutes  
(1)

- (b) What was Steve's average speed on his journey home?

25 km in 30 mins

∴ 50 km in 60 mins = 1 hr

..... 50 ..... km/h  
(2)

(Total for Question 16 is 3 marks)



17  $x - 1 = 2$

Work out the value of  $2x^2$

$$x = 3$$

$$2(3)^2 = 2 \times 9 = 18.$$

18

(Total for Question 17 is 3 marks)

DO NOT WRITE IN THIS AREA

DO NOT WRITE IN THIS AREA

DO NOT WRITE IN THIS AREA



18 The pie charts show information about the favourite animal of each student at school A and of each student at school B.

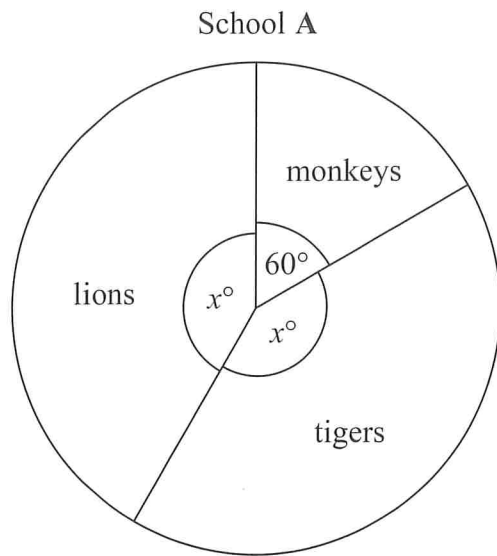

There are 480 students at school A.

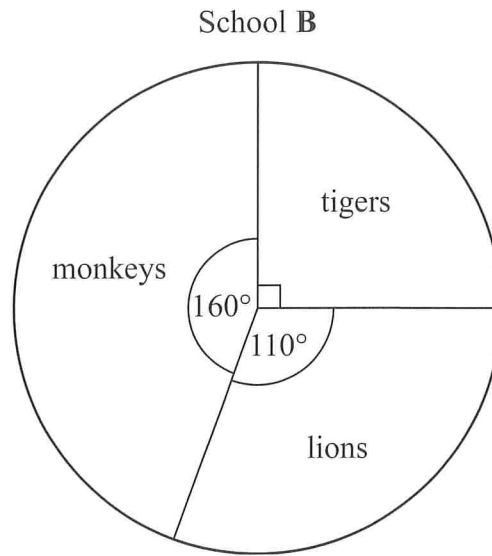

There are 760 students at school B.

Henry says,

“The same number of students at each school have tigers as their favourite animal.”

Is Henry correct?

You must show how you get your answer.

$$\begin{aligned}
 A \quad 2x + 60 &= 360 \\
 = \quad 2x &= 300 \\
 \quad x &= 150
 \end{aligned}$$

$$\begin{aligned}
 B \quad \frac{1}{4} \times 760 &= 190.
 \end{aligned}$$

$$\begin{array}{r}
 150 \times 480 \\
 \hline
 360
 \end{array}$$

$$= \frac{15}{36} \times 480$$

$$= \frac{5}{12} \times 480$$

$$= 5 \times 40$$

$$= 200.$$

HENRY IS NOT CORRECT.

SCHOOL A HAS 200 STUDENTS.  
SCHOOL B HAS 190 STUDENTS.

(Total for Question 18 is 4 marks)



19 Here is a number line.

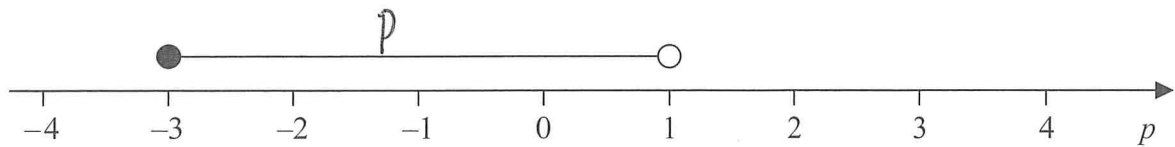

Write down the inequality shown on the number line.

$$-3 \leq p < 1$$

(Total for Question 19 is 2 marks)

20 Find the Lowest Common Multiple (LCM) of 108 and 120

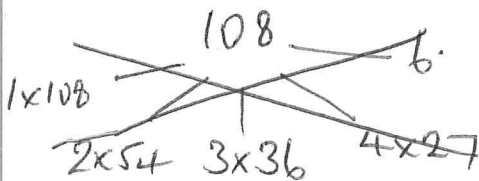

108    216    324    432    540    648    756  
 864    972    1080

120    240    360    480    600    720    840  
 960    1080

1080

(Total for Question 20 is 3 marks)



21 There are 60 people in a choir.

Half of the people in the choir are women.  $\frac{1}{2} \times 60 = 30$ .

The number of women in the choir is 3 times the number of men in the choir.

The rest of the people in the choir are children.

the number of children in the choir : the number of men in the choir =  $n : 1$

Work out the value of  $n$ .

You must show how you get your answer.

$$\text{NUMBER OF MEN} = \frac{30}{3} = 10,$$

$$\text{NUMBER OF MEN + WOMEN} = 10 + 30 = 40$$

$$\text{NUMBER OF CHILDREN} = 60 - 40 = 20.$$

$$\text{RATIO IS } 20 : 10 = 2 : 1$$

$$n = 2$$

(Total for Question 21 is 4 marks)

22 Work out  $1\frac{3}{4} \times 1\frac{1}{3}$

Give your answer as a mixed number.

$$1\frac{3}{4} \times 1\frac{1}{3} = \frac{28}{12} = \frac{14}{6} = \frac{7}{3} = 2\frac{1}{3}$$

$$2\frac{1}{3}$$

(Total for Question 22 is 3 marks)



23 Use a ruler and compasses to construct the line from the point  $P$  perpendicular to the line  $CD$ . You must show **all** construction lines.

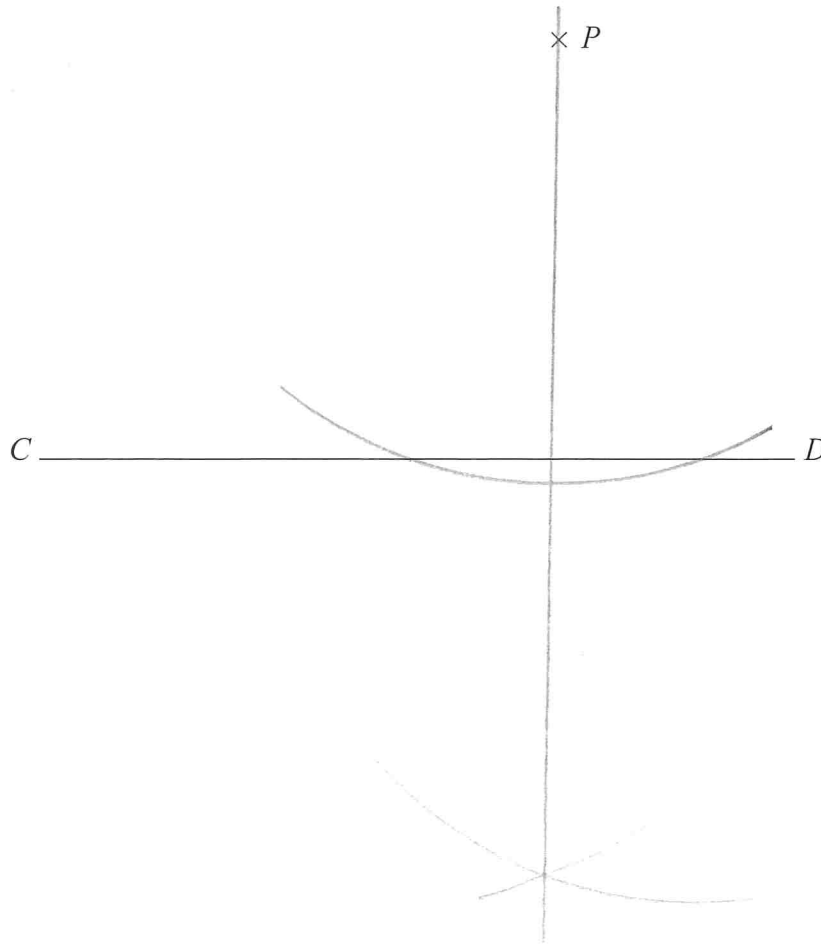

(Total for Question 23 is 2 marks)

DO NOT WRITE IN THIS AREA

DO NOT WRITE IN THIS AREA

DO NOT WRITE IN THIS AREA



24 The diagram shows triangle  $ABC$ .

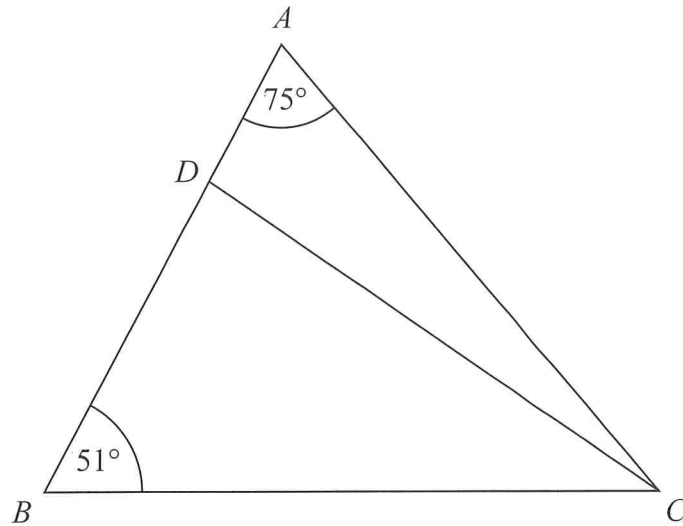

$ADB$  is a straight line.

the size of angle  $DCB$  : the size of angle  $ACD = 2 : 1$

Work out the size of angle  $BDC$ .

$$\hat{BCA} = 180 - 51 - 75 = 54$$

$$\begin{array}{l} 2 : 1 \quad 3 \\ 36 : 18 \quad 54 \downarrow \times 18 \end{array}$$

$$\hat{BDC} = 180 - 51 - 36 = 93$$

..... 93 °

(Total for Question 24 is 4 marks)



27 The accurate scale drawing shows the positions of port  $P$  and a lighthouse  $L$ .

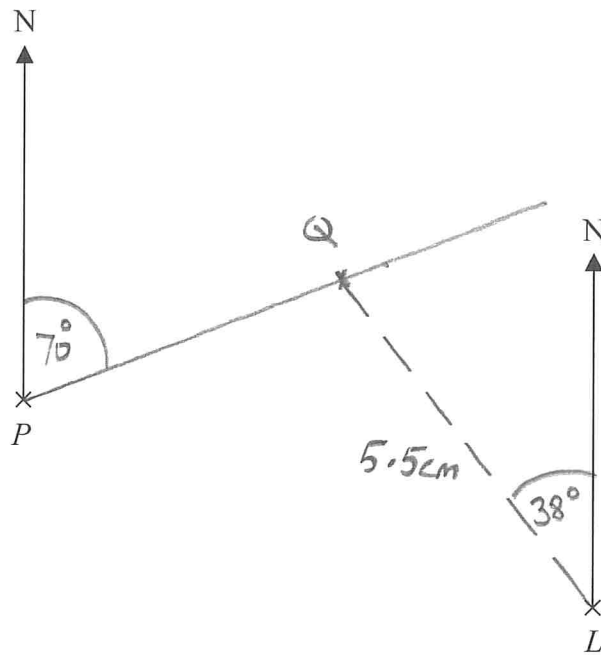

Scale: 1 cm represents 4 km.

Aleena sails her boat from port  $P$  on a bearing of  $070^\circ$

She sails for  $1\frac{1}{2}$  hours at an average speed of 12 km/h to a port  $Q$ .  $1\frac{1}{2} \times 12 = 18 \text{ km}$

Find

$$\frac{18}{4} = 4.5 \text{ cm}$$

- the distance, in km, of port  $Q$  from lighthouse  $L$ ,
- the bearing of port  $Q$  from lighthouse  $L$ .

$$5.5 \times 4 = 22$$

$$360 - 38 = 322$$

(20-23)

distance  $QL = 22$  km

bearing of  $Q$  from  $L = 322^\circ$

(317-330)

(Total for Question 27 is 5 marks)





28 The diagram shows triangle  $AOB$ .

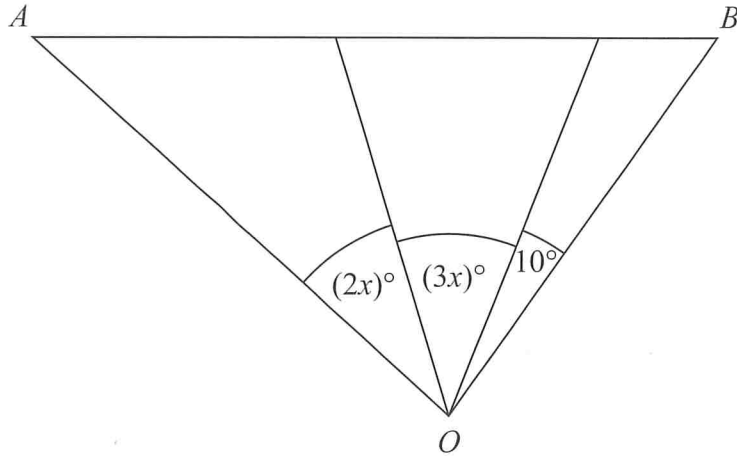

Angle  $AOB$  is **not** an obtuse angle.  $\therefore$  LESS THAN  $90^\circ$  (OR EQUAL TO  $90^\circ$ )

Find the greatest value of  $x$ .  
You must show all your working.

$$2x + 3x + 10 \leq 90$$

$$5x + 10 \leq 90$$

$$5x \leq 80$$

$$x \leq 16$$

$\therefore$  GREATEST VALUE = 16.

16°

(Total for Question 28 is 3 marks)



29  $ABC$  and  $PQR$  are similar right-angled triangles.

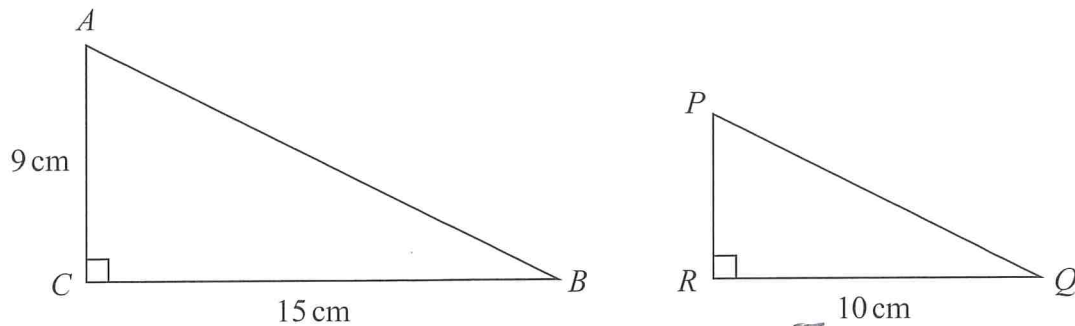

angle  $ABC =$  angle  $PQR$

(a) Work out the length of  $PR$ .

$$\frac{2}{3} \times 9 = 6$$

..... 6 ..... cm  
(2)

Triangle  $EGH$  is congruent to triangle  $KGF$ .

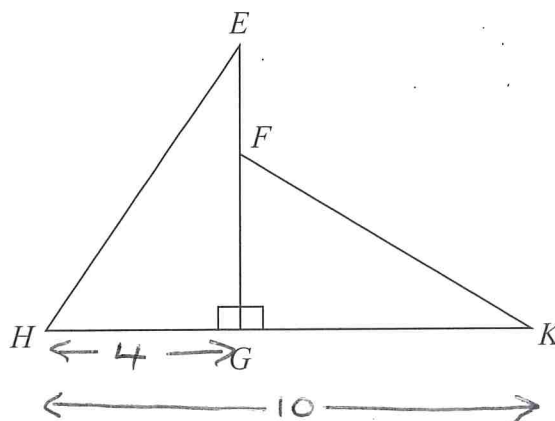

$HK = 10$  cm.

$HG = 4$  cm.

(b) Work out the length of  $EF$ .

$$GK = 10 - 4 = 6$$

$$\therefore EG = 6$$

$$FG = 4$$

$$\therefore EF = 6 - 4 = 2$$

..... 2 ..... cm  
(2)

(Total for Question 29 is 4 marks)

TOTAL FOR PAPER IS 80 MARKS

DO NOT WRITE IN THIS AREA

DO NOT WRITE IN THIS AREA

DO NOT WRITE IN THIS AREA

