

Write your name here

Surname

Other names

**Pearson Edexcel**  
**Level 1/Level 2 GCSE (9 - 1)**

Centre Number

--	--	--	--	--

Candidate Number

--	--	--	--

# Mathematics

## Paper 1 (Non-Calculator)

**Foundation Tier**

Specimen Papers Set 1

**Time: 1 hour 30 minutes**

Paper Reference

**1MA1/1F**

**You must have:** Ruler graduated in centimetres and millimetres, protractor, pair of compasses, pen, HB pencil, eraser.

Total Marks

### Instructions

- Use **black** ink or ball-point pen.
- **Fill in the boxes** at the top of this page with your name, centre number and candidate number.
- Answer **all** questions.
- Answer the questions in the spaces provided – *there may be more space than you need.*
- **Calculators may not be used.**
- Diagrams are **NOT** accurately drawn, unless otherwise indicated.
- You must **show all your working out.**



### Information

- The total mark for this paper is 80
- The marks for **each** question are shown in brackets – *use this as a guide as to how much time to spend on each question.*

### Advice

- Read each question carefully before you start to answer it.
- Keep an eye on the time.
- Try to answer every question.
- Check your answers if you have time at the end.

Turn over ►

S49815A

©2015 Pearson Education Ltd.



**PEARSON**

Answer ALL questions.

Write your answers in the spaces provided.

You must write down all the stages in your working.

1 Change 530 centimetres into metres.

5.3 metres

(Total for Question 1 is 1 mark)

2 How many minutes are there in  $3\frac{1}{4}$  hours?

$$\begin{aligned} & 3 \times 60 + \frac{1}{4} \times 60 \\ & = 180 + 15 \end{aligned}$$

195 minutes

(Total for Question 2 is 1 mark)

3 Write 4.4354 correct to 2 decimal places.

4.44

(Total for Question 3 is 1 mark)

4 Write 0.9 as a percentage.

90 %

(Total for Question 4 is 1 mark)

DO NOT WRITE IN THIS AREA

DO NOT WRITE IN THIS AREA

DO NOT WRITE IN THIS AREA

DO NOT WRITE IN THIS AREA

DO NOT WRITE IN THIS AREA

DO NOT WRITE IN THIS AREA

5 Work out  $(-3)^3$

$-3 \times -3 \times -3$

$-27$

(Total for Question 5 is 1 mark)

6 Here are four cards.  
There is a number on each card.

4

5

2

1

(a) Write down the largest 4-digit even number that can be made using each card only once.

$5412$   
(2)

(b) Write down all the 2-digit numbers that can be made using these cards.

- |    |    |    |    |
|----|----|----|----|
| 45 | 54 | 24 | 14 |
| 42 | 52 | 25 | 15 |
| 41 | 51 | 21 | 12 |

(2)

(Total for Question 6 is 4 marks)

7 The table shows information about the sports some students like best.

	Hockey	Tennis	Football	Golf
Boys	3	8	15	9
Girls	6	14	7	1

Draw a suitable diagram or chart for this information.

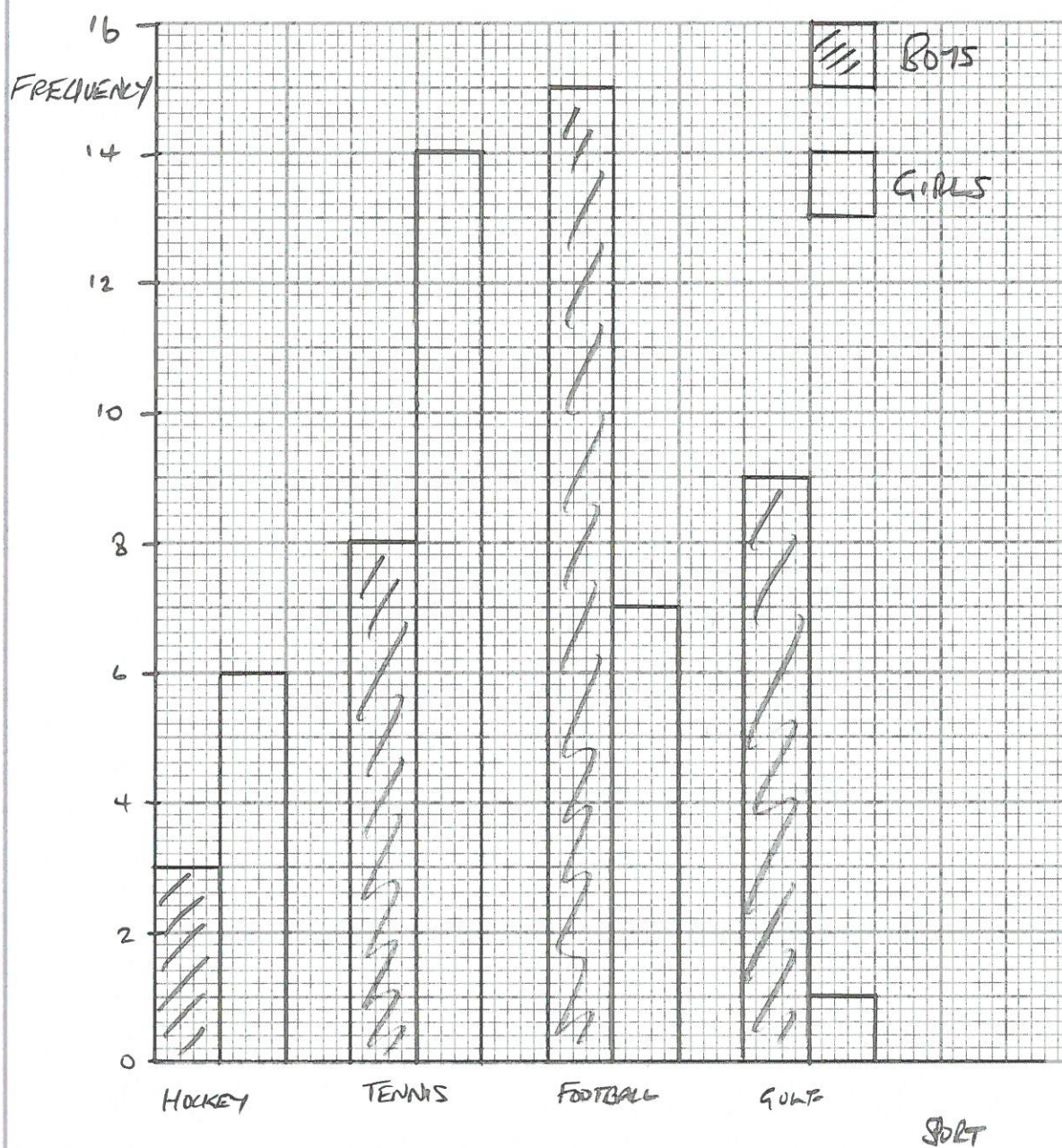

(Total for Question 7 is 4 marks)

DO NOT WRITE IN THIS AREA

DO NOT WRITE IN THIS AREA

DO NOT WRITE IN THIS AREA

DO NOT WRITE IN THIS AREA

8 Bernard says,

“When you halve a whole number that ends in 8, you always get a number that ends in 4”

(a) Write down an example to show that Bernard is wrong.

$\frac{1}{2}$  OF 18 = 9

(1)

Alice says,

“Because 7 and 17 are both prime numbers, all whole numbers that end in 7 are prime numbers.”

(b) Is Alice correct?

You must give a reason with your answer.

NO - 27 ENDS IN 7 BUT  $9 \times 3 = 27$  SO 27 IS NOT PRIME

(1)

(Total for Question 8 is 2 marks)

9 Work out  $247 \times 63$

$$\begin{array}{r}
 247 \\
 \times 63 \\
 \hline
 741 \\
 14820 \\
 \hline
 15561
 \end{array}$$

15561

(Total for Question 9 is 3 marks)



10 An American airline has a maximum size for bags on its planes. The diagram shows the maximum dimensions.

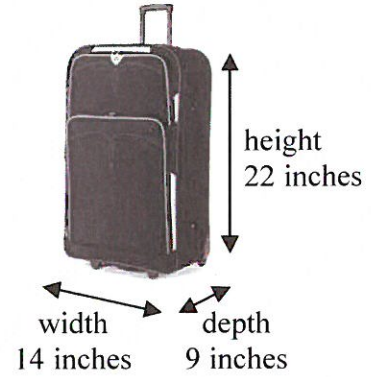

Chris has a bag.

It has  
 height 50 cm  
 width 40 cm  
 depth 20 cm

1 inch = 2.54 cm

Can Chris take this bag on the plane?  
 You must show your working.

width:  $14 \times 2.54 \text{ cm}$   
 $= 35.56 \text{ cm}$

$$\begin{array}{r} 254 \\ 14 \\ \hline 1016 \\ 2540 \\ \hline 3556 \end{array}$$

CHRIS IS NOT ALLOWED TO TAKE THIS BAG BECAUSE THE ALLOWANCE IS 35.56cm AND HIS BAG IS 40cm,

(Total for Question 10 is 3 marks)

11 Complete the two-way table.

	blue eyes	brown eyes	green eyes	total
boys	5	3	4	12
girls	6	7	5	18
total	11	10	9	30

(Total for Question 11 is 3 marks)

12 There are 28 red pens and 84 black pens in a bag.

Write down the ratio of the number of red pens to the number of black pens.  
Give your ratio in its simplest form.

$$\begin{array}{l} 28 : 84 \\ \div 7 \downarrow \\ 4 : 12 \\ \div 4 \downarrow \\ 1 : 3 \end{array}$$

$$\underline{\quad 1 : 3 \quad}$$

(Total for Question 12 is 2 marks)

13 Here is a sequence of patterns made with grey square tiles and white square tiles.

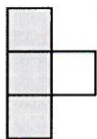

pattern number

1

4

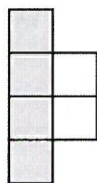

pattern number

2

6

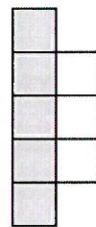

pattern number

3

8

(a) In the space below, draw pattern number 4

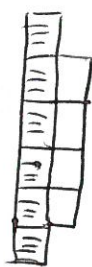

(1)

(b) Find the total number of tiles in pattern number 20

$$2 \times 20 + 2$$

$$402$$

(2)

(c) Write an expression, in terms of  $n$ , for the number of grey tiles in pattern number  $n$ .

$$3, 4, 5, \dots$$

$$n+2$$

(2)

(Total for Question 13 is 5 marks)



14 A unit of gas costs 4.2 pence.

On average Ria uses 50.1 units of gas a week.  
She pays for the gas she uses in 13 weeks.

(a) Work out an estimate for the amount Ria pays.

$10 \times 4 \times 50 = 2000p = £20$

$£20$   
 $(£20 - £26)^{(3)}$

(b) Is your estimate to part (a) an underestimate or an overestimate?  
Give a reason for your answer.

UNDER ESTIMATE SINCE EACH NUMBER HAS BEEN ROUNDED  
DOWN.

(1)

(Total for Question 14 is 4 marks)

15 This is a scale plan of a rectangular floor.

$$3.9 \text{ cm.} \\ = 7.8 \text{ m.}$$

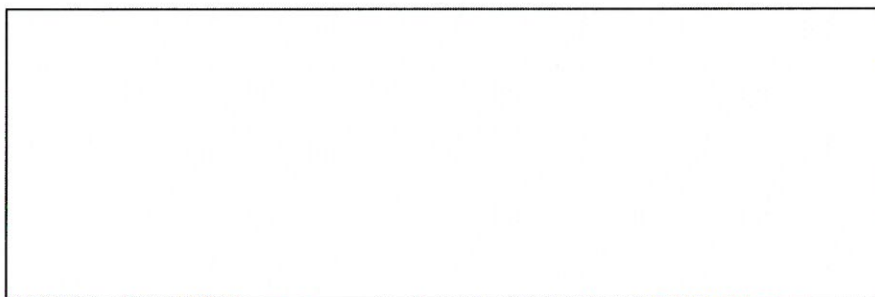

Diagram  
accurately  
drawn

$$11.5 \text{ cm} = 23 \text{ m}$$

Scale: 1 cm represents 2 m

Mrs Bridges is going to cover the floor with boards.  
Each board is rectangular in shape.

Each board is 1.2 m long and 1 m wide.

Mrs Bridges has 150 boards.

Does she have enough boards?

You must show how you get your answer.

NEEDS 20 BOARDS FOR LENGTH SINCE  $20 \times 1.2 = 24 \text{ m}$   
( $\therefore$  19 BOARDS WOULD DO ONLY  $24 - 1.2 = 22.8 \text{ m}$  WHICH IS NOT ENOUGH)

NEEDS ~~8~~<sup>8</sup> BOARDS FOR WIDTH

$\therefore$  NEEDS  $8 \times 20 = 160$  BOARDS.

$\therefore$  MRS. BRIDGES DOES NOT HAVE ENOUGH.

(Total for Question 15 is 3 marks)

16

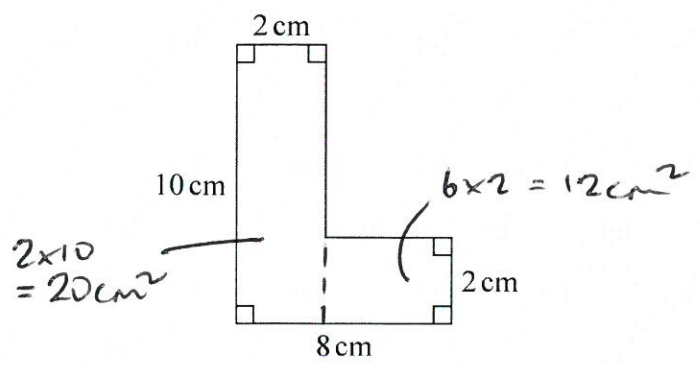

Work out the area of the shape.

$20 + 12 = 32$

..... 32 cm<sup>2</sup>

(Total for Question 16 is 2 marks)

17

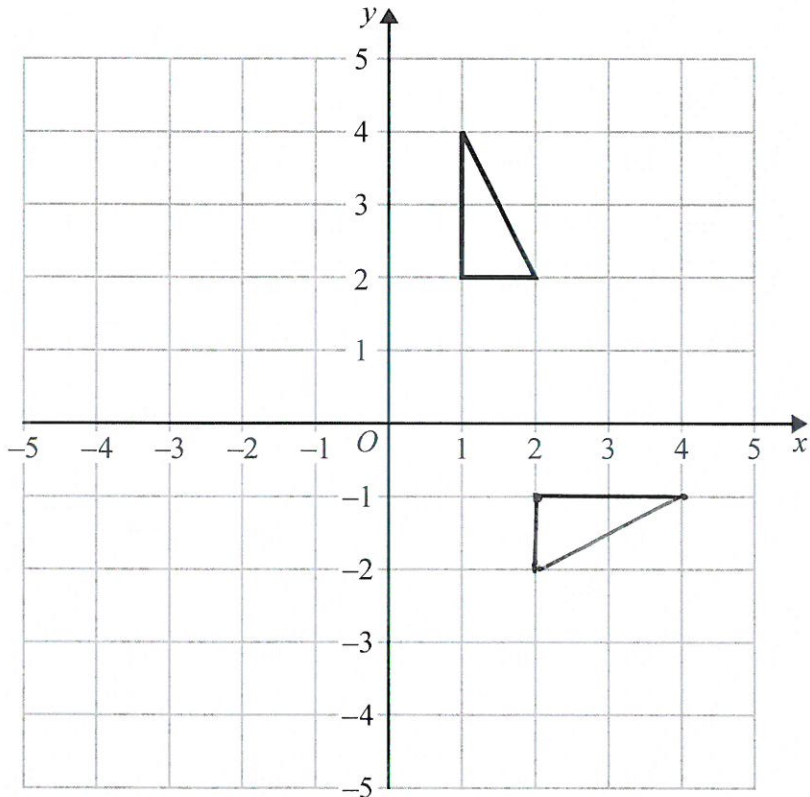

On the grid, rotate the triangle 90° clockwise about (0, 0).

(Total for Question 17 is 2 marks)

18 There are 500 passengers on a train.

$\frac{7}{20}$  of the passengers are men.  $\frac{7}{20} \times 500 = \frac{7}{2} \times 50 = 7 \times 25 = 175$

40% of the passengers are women.  $\frac{40}{100} \times 500 = 40 \times 5 = 200$

The rest of the passengers are children.

Work out the number of children on the train.

$$200 + 175 = 375$$

$$500 - 375 = 125$$

125

(Total for Question 18 is 3 marks)

19 A shop sells milk in 1 pint bottles and in 2 pint bottles.

Each 1 pint bottle of milk costs 52p.

Each 2 pint bottle of milk costs 93p.

Martin has **no** milk.

He assumes that he uses, on average,  $\frac{3}{4}$  of a pint of milk each day.

Martin wants to buy enough milk to last for 7 days.

- (a) Work out the smallest amount of money Martin needs to spend on milk. You must show all your working.

FOR 7 DAYS HE NEEDS  $\frac{3}{4} \times 7 = \frac{21}{4} = 5\frac{1}{4}$  PINTS

∴ MUST BUY 6 PINTS

COULD BUY: 3 2 PINTS ∴  $3 \times 93p = \pounds 2.79$

6 1 PINT ∴  $6 \times 52p = \pounds 3.12$

£ 2.79  
(3)

Martin actually uses more than  $\frac{3}{4}$  of a pint of milk each day.

- (b) Explain how this might affect the amount of money he needs to spend on milk.

HE MIGHT STILL USE LESS THAN 6 PINTS WHICH MEANS HE  
WOULD SPEND THE SAME. IF HE USES MORE THAN 6 PINTS  
HE WILL SPEND MORE.

(1)

(Total for Question 19 is 4 marks)

20 The diagram shows a right-angled triangle.

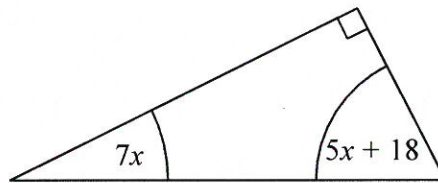

All the angles are in degrees.

Work out the size of the smallest angle of the triangle.

$$7x + 5x + 18 + 90 = 180$$

$$\therefore 12x + 108 = 180$$

$$\therefore 12x = 72$$

$$\therefore x = 6$$

$$7x = 7 \times 6 = 42$$

$$5x + 18 = 5 \times 6 + 18 = 48$$

42°

(Total for Question 20 is 3 marks)

21 A box exerts a force of 140 newtons on a table.

The pressure on the table is 35 newtons/m<sup>2</sup>.

Calculate the area of the box that is in contact with the table.

$$p = \frac{F}{A}$$

$p$  = pressure

$F$  = force

$A$  = area

$$35 = \frac{140}{A}$$

$$\therefore A = \frac{140}{35} = 4$$

4 m<sup>2</sup>

(Total for Question 21 is 3 marks)

- 22 There are only red counters, blue counters, green counters and yellow counters in a bag.

The table shows the probabilities of picking at random a red counter and picking at random a yellow counter.

Colour	red	blue	green	yellow
Probability	0.24	0.22	0.22	0.32

The probability of picking a blue counter is the same as the probability of picking a green counter.

Complete the table.

$$0.24 + 0.32 = 0.56$$

$$1 - 0.56 = 0.44$$

$$\frac{0.44}{2} = 0.22$$

(Total for Question 22 is 2 marks)

- 23 A pattern is made using identical rectangular tiles.

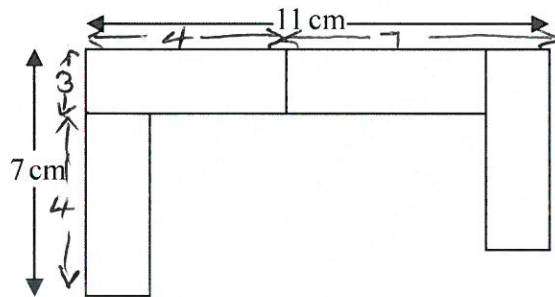

Find the total area of the pattern.

$$\text{EACH RECTANGLE IS } 4 \times 3 = 12 \text{ cm}^2$$

$$\therefore \text{ FOR 4 RECTANGLES } 4 \times 12 = 48 \text{ cm}^2$$

48 cm<sup>2</sup>

(Total for Question 23 is 4 marks)

- 24 The diagram shows a sand pit.  
The sand pit is in the shape of a cuboid.

Sally wants to fill the sand pit with sand.  
A bag of sand costs £2.50  
There are 8 litres of sand in each bag.

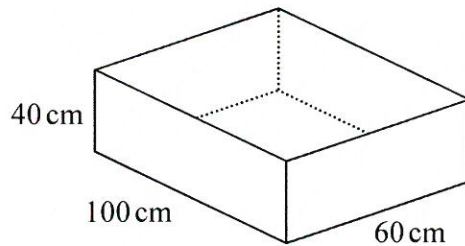

Sally says,

“The sand will cost less than £70”

Show that Sally is wrong.

$$\begin{aligned}\text{VOLUME OF SAND PIT} &= 40 \times 100 \times 60 \\ &= 240000 \text{ cm}^3\end{aligned}$$

$$1 \text{ LITRE} = 1000 \text{ cm}^3 \quad \therefore \text{VOLUME} = 240 \text{ L}$$

$$\therefore \text{NEED } \frac{240}{8} = 30 \text{ BAGS}$$

$$\text{COST} = 30 \times \text{£}2.50 = \text{£}75.$$

$\therefore$  SALLY IS WRONG. THE SAND COSTS MORE THAN £70.

(Total for Question 24 is 5 marks)

DO NOT WRITE IN THIS AREA

DO NOT WRITE IN THIS AREA

DO NOT WRITE IN THIS AREA



- 25 Four friends each throw a biased coin a number of times.  
The table shows the number of heads and the number of tails each friend got.

	Ben	Helen	Paul	Sharif	
heads	34	66	80	120	300
tails	8	12	40	40	100
	42	78	120	160	400

The coin is to be thrown one more time.

- (a) Which of the four friends' results will give the best estimate for the probability that the coin will land heads?  
Justify your answer.

SHARIF - HE THREW THE COIN MOST TIMES, i.e.  
BIGGEST NUMBER OF TRIALS

(1)

Paul says,

"With this coin you are twice as likely to get heads as to get tails."

- (b) Is Paul correct?  
Justify your answer.

FOR PAUL'S DATA  $\frac{80}{120}$  HEADS =  $\frac{2}{3}$   $\therefore$  PAUL IS  
CORRECT SINCE  $\frac{2}{3}$  IS TWICE  $\frac{1}{3}$ .

(2)

The coin is to be thrown twice.

- (c) Use all the results in the table to work out an estimate for the probability that the coin will land heads both times.

$$P(H) = \frac{3}{4}$$

$$\therefore \frac{3}{4} \times \frac{3}{4} = \frac{9}{16}$$

$$\frac{9}{16}$$

(2)

(Total for Question 25 is 5 marks)

26 (a) Write down the exact value of  $\cos 30^\circ$

$$\frac{\sqrt{3}}{2}$$

(1)

(b)

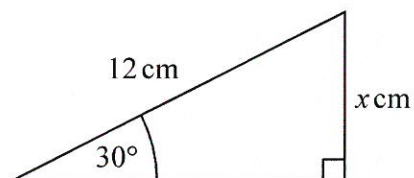

Given that  $\sin 30^\circ = 0.5$ ,  
work out the value of  $x$ .

$$\begin{aligned}\sin 30 &= \frac{x}{12} \\ \therefore x &= 12 \sin 30 \\ &= 12 \times \frac{1}{2} \\ &= 6\end{aligned}$$

6

(2)

(Total for Question 26 is 3 marks)

27 Expand and simplify  $(x + 3)(x - 1)$

$$\begin{aligned}x^2 - x + 3x - 3 \\ = x^2 + 2x - 3\end{aligned}$$

$$x^2 + 2x - 3$$

(Total for Question 27 is 2 marks)

DO NOT WRITE IN THIS AREA

DO NOT WRITE IN THIS AREA

DO NOT WRITE IN THIS AREA

28 Factorise  $x^2 - 16$

$$(x+4)(x-4)$$

(Total for Question 28 is 1 mark)

29 Solve the simultaneous equations

$$\begin{aligned} 4x + y &= 25 \quad \times 3 \\ x - 3y &= 16 \\ \hline 12x + 3y &= 75 \\ \hline 13x &= 91 \\ x &= 7 \end{aligned}$$

$$\begin{aligned} 4 \times 7 + y &= 25 \\ 28 + y &= 25 \\ y &= -3 \end{aligned}$$

$$x = 7, y = -3$$

(Total for Question 29 is 3 marks)

TOTAL FOR PAPER IS 80 MARKS

